

TO: All owners and operators of Model 206L-1, 206L-3 and 206L-4 helicopters

SUBJECT: ENGINE FOREIGN OBJECT DAMAGE (FOD), PREVENTION OF

Bell Helicopter has recently introduced carbon fiber inlet cowling 407-064-010-101 / -103 on production aircraft (206L4 S/N 52454 and Sub). This new cowling is also available for Spare replacement to all aircraft.

These cowlings are configured with nutplates 90-104C08-1 that are bonded on the inner surface to mount the inspection window. The 90-104C08-1 nutplate is designed with a replaceable nut element that is held in place by a retaining clip.

Bell Helicopter encourages maintainers to carefully inspect the nutplates for integrity when removing/reinstalling the inspection window. This practice may prevent a broken nutplate to become FOD to the engine.

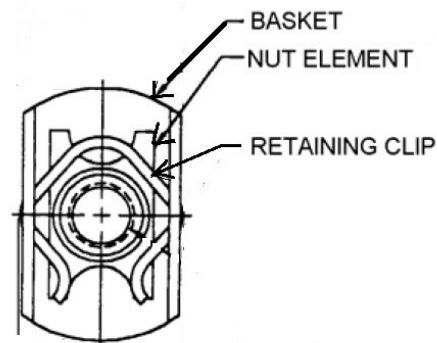

90-104C08-1 nutplate

For any questions regarding this letter, please contact:

Bell Helicopter Product Support Engineering - Light Helicopters
Tel: 450-437-2862 / 1-800-363-8023 / pselight@bh.com