



A Textron Company

TECHNICAL BULLETIN

412-19-243

15 April 2019

MODEL AFFECTED: 412

SUBJECT: MAIN DRIVESHAFT RETAINER P/N 205-040-175-001, MODIFICATION OF

HELICOPTERS AFFECTED: Serial numbers 33001 through 33213, 34001 through 34024 and, 36001 through 36019.

COMPLIANCE: At customer's option.

DESCRIPTION:

This Bulletin introduces a product modification to the 205-040-175-001 retainers of the 212-040-005-103 driveshaft assemblies to improve grease retention. The modification consists of drilling a vent hole in the center of the Retainer P/N 205-040-175-001.

The new spares retainer configuration, 205-040-175-115, will have a vent hole drilled in the center. Once this technical bulletin is accomplished, the 205-040-175-001 retainer will be equivalent to the 205-040-175-115.

Applicability of this bulletin to any spare part shall be determined prior to its installation on an affected helicopter.

APPROVAL:

The engineering design aspects of this bulletin are FAA approved for FAA certified helicopters as listed in the applicable Type Certificate Data Sheet. For non FAA certified helicopters, the engineering design aspects of this bulletin are Bell Helicopter Engineering approved.

CONTACT INFO:

For any questions regarding this bulletin, please contact:

Bell Product Support Engineering
MEDIUM Tel: 450-437-6201 / 1-800-363-8028 / productsupport@bellflight.com

MANPOWER:

Approximately 4.0 man-hours are required to complete this bulletin. This estimate is based on hands-on time and may vary with personnel and facilities available.

WARRANTY:

There is no warranty credit applicable for parts or labor associated with this bulletin.

MATERIAL:

Required Material:

None required.

Consumable Material:

The following material is required to accomplish this bulletin, but may not require ordering, depending on the operator’s consumable material stock levels. This material may be obtained through your Bell Supply Center.

<u>Part Number</u>	<u>Nomenclature</u>	<u>Qty (Note)</u>	<u>Reference *</u>
2110-07015-00	PD680 Solvent	A/R (1)	C-304
2010-00113-00	Sealant, low adhesion	A/R (1)(2)	C-328
2100-00030-00	Chemical Film (Alodine)	A/R (1)	C-100

* C-XXX numbers refer to the consumables list in the BHT-ALL-SPM, Standard Practices Manual

NOTES:

1. This consumable item may already be in customer’s stock.
2. Optional

SPECIAL TOOLS:

None required.

WEIGHT AND BALANCE:

Negligible.

ELECTRICAL LOAD DATA:

Not affected.

REFERENCES:

BHT-412-IPB, Illustrated Parts Breakdown
BHT-412-MM, Maintenance Manual
BHT-ALL-Standard Practices Manual
BHT-412-CR&O, Component Repair and Overhaul Manual

PUBLICATIONS AFFECTED:

BHT-412-IPB, Illustrated Parts Breakdown.

ACCOMPLISHMENT INSTRUCTIONS:

1. Prepare the helicopter for maintenance.
2. Remove the main driveshaft assembly from the helicopter (BHT-412-MM, Chapter 63).
3. Remove the grease retainers P/N 205-040-175-001 from each end of the main driveshaft assembly P/N 212-040-005-103 (BHT-412-CR&O, Chapter 63).
4. Thoroughly clean the retainers using dry cleaning solvent (C-304) and dry the parts using dry filtered compressed air.
5. Secure the retainers flat and drill a 0.092 – 0.097-inch diameter hole directly in the center of each retainer as shown in Figure 1.
6. Deburr the holes to remove sharp edges.
7. Carry out chemical film treatment (alodine) (C-100) on the repaired areas (BHT-ALL-SPM, Chapter 3).

-NOTE-

Prior to re-assembly of the main driveshaft, inspect the condition of the boots as well as the inner and outer couplings. Lubricate couplings as required. (BHT-412-CR&O, Chapter 63).

8. Re-install the retainers on the main driveshaft. (BHT-412-CR&O, Chapter 63).
9. Application of a small bead of low adhesion sealant (C-328) between the mating surfaces as shown in Figure 2 is optional.
10. Make an entry on the helicopter logbook and historical service records indicating compliance with this Technical Bulletin.

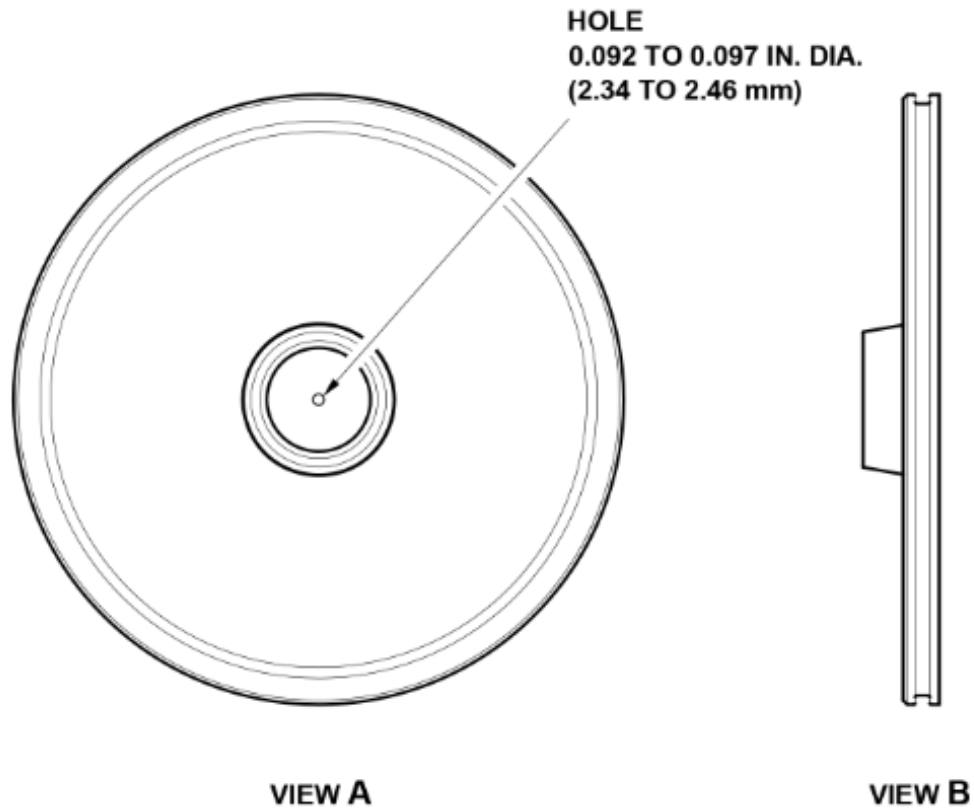

Figure 1 – Grease Retainer

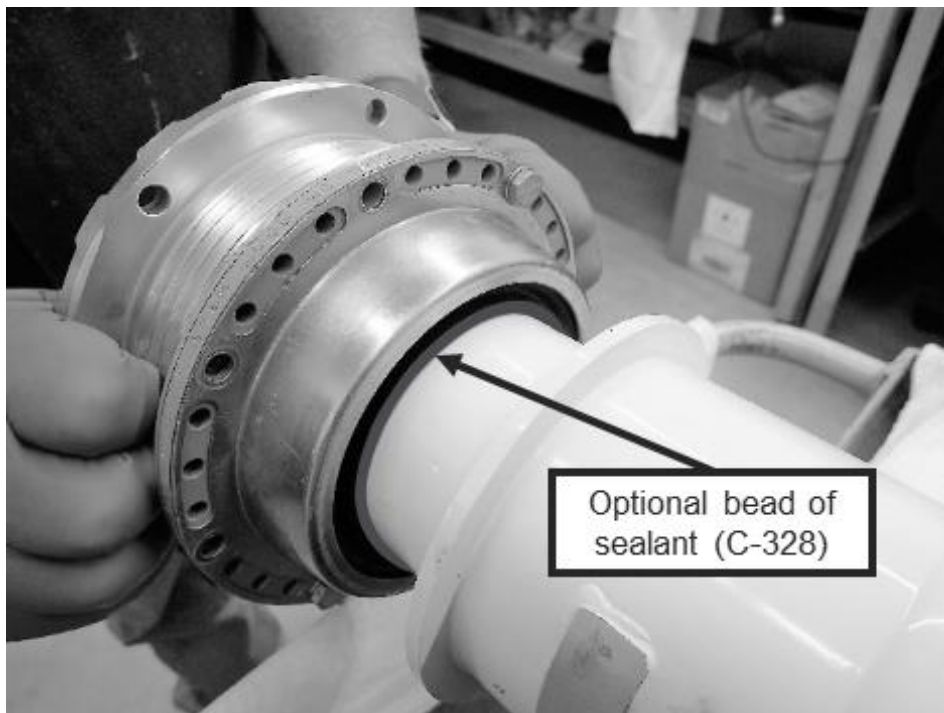
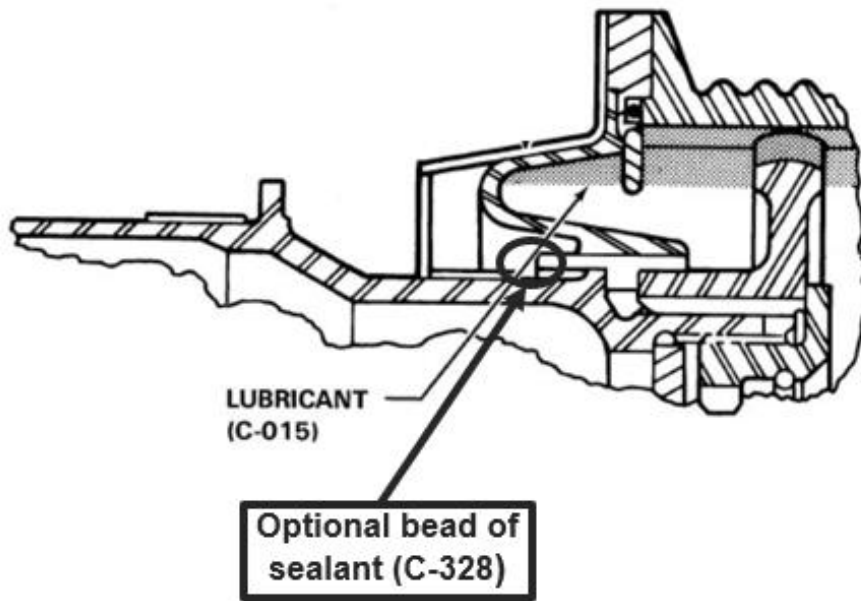

Figure 2 – Main Driveshaft Coupling Assembly