

TECHNICAL BULLETIN
Bell Helicopter **TEXTRON**

A Subsidiary of Textron Inc.

No. 222-05-173

Date Dec 08, 2005

Page 1 of 4

DATE
REV

MODEL AFFECTED: 222 and 222B

SUBJECT: LANDING GEAR ACTUATOR P/N 222-336-001-015, INTRODUCTION OF

HELICOPTERS AFFECTED: Model 222 helicopters serial number 47006 through 47089
Model 222B helicopters serial number 47131 through 47156

COMPLIANCE: At Customer's Option

DESCRIPTION:

The current extend/retract actuators P/N 222-336-001-007 have been subject of many complaints from the operators.

A new design actuator, interchangeable with the existing component, has been created. Improvements have been made to the dynamic seals as well as adding a friction reducing coating to the surfaces that are in contact during stroking of the actuator.

This bulletin is issued to introduce the new actuator P/N 222-336-001-015 which will greatly increase the service life of the actuator. In addition, the latest revision of the retract actuator component maintenance and overhaul manual P/N 32-31-01 dated May 31, 2005 is included with this bulletin.

APPROVAL:

The engineering design aspects of this bulletin are Transport Canada Civil Aviation (TCCA) approved.

MANPOWER:

Approximately 2.0 man-hours are required to replace each actuator. Man-hours are based on hands-on time, and may vary with personnel and facilities available.

SPECIAL PRICING POLICY:

Bell Helicopter is offering the improved actuators P/N 222-336-001-015 at a special introductory price of \$5300.00 (per unit) until October 1, 2006.

To receive this special price:

1. Customers must order the new actuators P/N 222-336-001-015 from a Bell Helicopter approved spares supply source.

-NOTE-

Customers must have parts on order by October 1, 2006 to receive this SPECIAL PRICE OF U.S. \$ 5300.00 per actuator.

2. Order parts no later than October 1, 2006.
3. The owner must make sure to specify he is completing this Technical Bulletin. You will be asked to give the serial number of the helicopter on which the actuator will be installed.

Bell helicopter is also offering the improved actuators P/N 222-336-001-015 at an exchange price of \$3200.00 (per unit)

-NOTE-

Bell Helicopter does not recommend upgrading the existing actuator to the 222-336-001-015 configuration without reworking the piston rod and the housing surfaces.

MATERIALS:

Required Material:

The following material is required for the accomplishment of this bulletin and may be obtained through your Bell Helicopter Textron Supply Center.

<u>Part Number</u>	<u>Nomenclature</u>	<u>Quantity</u>
222-336-001-015	Actuator	3 per a/c
MS28778-4	Packing	3 per a/c
MS28778-6	Packing	3 per a/c
MS28773-06	Retainer	3 per a/c

Consumable Material:

The following material is required to accomplish this bulletin, however this material is considered consumable (bench stock) material and may not require ordering depending on the operators consumable material stock levels. This material may be obtained through your Bell Helicopter Textron Supply Center.

<u>Part Number</u>	<u>Nomenclature</u>	<u>Quantity</u>	<u>Reference</u>
MIL-H-5606	Hydraulic fluid	A/R	C-002

SPECIAL TOOLS:

None required

WEIGHT AND BALANCE:

No change

ELECTRICAL LOAD DATA:

Not affected

REFERENCES:

BHT-222/222B-MM-1, Chapter 29 and 32
 BHT-222-IPB, Chapter 29 and 32
 BHT-222B-IPB, Chapter 29 and 32
 BHT-222-CR&O-V.1, Chapter 32

PUBLICATIONS AFFECTED:

BHT-222/222B-MM-1, Chapter 29 and 32
 BHT-222-IPB, Chapter 29 and 32
 BHT-222B-IPB, Chapter 29 and 32
 BHT-222-CR&O-V.1, Chapter 32

ACCOMPLISHMENT INSTRUCTIONS:**-NOTE-**

It is permissible to install one or more new actuator(s) 222-336-001-015 with one or more old configuration actuator(s) P/N 222-336-001-007 on the same aircraft.

-NOTE-

The procedure to remove/install one actuator is listed. The procedure to remove/install the other actuators is the same

1. Remove existing extend/retract actuator from the aircraft. Refer to BHT-222/222B-MM-1, Chapter 32.
2. Install new actuator P/N 222-336-001-015. Refer to BHT-222/222B-MM-1, Chapter 32, except prior to installation, the actuator must be filled/flushed with hydraulic fluid (C-002) as follows:

-NOTE-

Extend and retract hydraulic hoses will have to be removed from the aircraft and installed on the actuator to allow bleeding of the new actuator prior to its installation.

- A. Install hydraulic packings, fittings and extend and retract hydraulic hoses onto the actuator.
 - B. Fill both the retract and extend ports of the actuator with Hydraulic fluid. (C-002)
 - C. With the end of both hydraulic hoses submerged in a container filled with hydraulic fluid (C-002), fully extend then fully compress the piston rod of the actuator to bleed air out of the actuator.
 - D. Remove hydraulic hose ends from the fluid and install a cap on each hose.
3. Proceed with installation of the actuator in accordance with the procedure in BHT-222/222B-MM-1, Chapter 32.
 4. Remove existing retract actuator component maintenance and overhaul manual P/N 32-31-01 from BHT-222-CR&O-V.1, Chapter 32 and insert revised retract actuator component maintenance and overhaul manual P/N 32-31-01 dated May 31, 2005
 5. Annotate the helicopter records to reflect compliance with this bulletin.



COMPONENT MAINTENANCE AND OVERHAUL MANUAL
OMP3974

TO: HOLDERS OF RETRACT ACTUATOR PART NO. OMP3974 COMPONENT MAINTENANCE AND OVERHAUL MANUAL WITH ILLUSTRATED PARTS LIST.

REVISION NO. 3 DATED MAY 31/05

HIGHLIGHTS

All pages have been affected by this revision. Major changes are outlined below together with the highlights of the revision. Replace existing copies of this manual with the completely revised edition.

Chapter/Section And Page No.	Description of Change	Effectivity
32-31-01 Title, RR-1, LEP-1, and all subsequent pages	Revision 3 is submitted as a complete revision that reflects changing from OMP3974-1 to the OMP3974 series masthead. Added OMP3974-3 part number. Added annotation of Change 3 and date of May 31/05.	All
32-31-01 Intro-1	Added part number OMP3974-3.	All
32-31-01 Page 1	Added part number OMP3974-3. Changed hydraulic fluid specification to MIL-PRF-5606. Added dry weight of 1.46 pounds (0.663 kg) for OMP3974-3.	All
32-31-01 101	Changed hydraulic fluid specification to MIL-PRF-5606. Revised piston rod stroke dimensions. Added corrective action for fluid leakage for OMP3974-3.	All
32-31-01 301	Added items 15A, 20A, 32, 35, 40A, 47, and 57 to disassembly procedures. Added new steps for removing AGT ring seals.	All
32-31-01 501	Updated reference for magnetic particle inspection. Added items 20A and 40A to check procedures.	All
32-31-01 601 603 and 604	Added reference for upgrading procedures. Added item 40A to repair procedures. Added paragraphs 4 and 5 containing procedures for upgrading and repairing the OMP3974-1 to OMP3974-3.	All



HTD Aerospace, Inc.

A Triumph Group Company

COMPONENT MAINTENANCE AND OVERHAUL MANUAL
OMP3974

Chapter/Section And Page No.	Description of Change	Effectivity
32-31-01 701 702	Changed hydraulic fluid specification to MIL-PRF-5606. Added items 15A, 20A, 32, 40A, 47, and 57 to assembly procedures. Added new steps for installing AGT ring seals.	All
32-31-01 801	Added items 20A and 40A to Table 801. Added torque value for OMP3974-3.	All
32-31-01 1004	Added vendor code and address for Greene Tweed and Co.	All
1006	Revised Figure 1 to show parts of both OMP3974-1 and OMP3974-3.	All
1007	Added items 1A, 15A, 20A, 32, 40A, 47, and 57 to parts list with part numbers.	All



HTD Aerospace, Inc.

A Triumph Group Company

**COMPONENT MAINTENANCE
AND OVERHAUL MANUAL
WITH
ILLUSTRATED PARTS LIST**

Retract Actuator

Part No. OMP3974-1

Part No. OMP3974-3

32-31-01

**OCTOBER 1, 1979
REVISED MAY 31, 2005**



HTD Aerospace, Inc.

A Triumph Group Company

COMPONENT MAINTENANCE AND OVERHAUL MANUAL
OMP3974

THE SERVICE BULLETINS ON THIS PAGE ARE INCLUDED IN THIS MANUAL

SERVICE BULLETIN LIST

BULLETIN NO.	DATE INCORPORATED	BULLETIN NO.	DATE INCORPORATED



COMPONENT MAINTENANCE AND OVERHAUL MANUAL
OMP3974

LIST OF EFFECTIVE PAGES

The List of Effective Pages records not only each page of subject revision but also each previously issued page which is still correct. Pages which are no longer current do not appear on this list. If there is any question about the currency of the recipient's copy, it is recommended that each page of the manual be checked off against this List of Effective Pages. Any page which does not check out with this list, either by number or by date, shall be discarded.

<u>Subject</u>	<u>Page</u>	<u>Date</u>	<u>Subject</u>	<u>Page</u>	<u>Date</u>
Title		May 31/05	Cleaning	401	May 31/05
				402	May 31/05
Record of Revisions	RR-1	May 31/05			
	RR-2	Blank	Check	501	May 31/05
				502	May 31/05
Record of Temporary Revisions	RTR-1	May 31/05			
	RTR-2	Blank	Repair	601	May 31/05
				602	May 31/05
Service Bulletin List	SBL-1	May 31/05		603	May 31/05
	SBL-2	Blank		604	Blank
List of Effective Pages	LEP-1	May 31/05	Assembly	701	May 31/05
	LEP-2	Blank		702	May 31/05
Table of Contents	TOC-1	May 31/05	Fits and	801	May 31/05
	TOC-2	Blank	Clearances	802	Blank
Introduction	INTRO-1	May 31/05	Special Tools,	901	May 31/05
	INTRO-2	Blank	Fixtures, and	902	Blank
			Equipment		
Description and Operation	1	May 31/05			
	2	Blank	Illustrated Parts	1001	May 31/05
			List	1002	May 31/05
Testing and Fault Isolation	101	May 31/05		1003	May 31/05
	102	Blank		1004	May 31/05
				1005	Blank
Disassembly	301	May 31/05		1006	May 31/05
	302	Blank		1007	May 31/05
				1008	Blank



HTD Aerospace, Inc.

A Triumph Group Company

COMPONENT MAINTENANCE AND OVERHAUL MANUAL
OMP3974

TABLE OF CONTENTS

	Page
Description and Operation.....	1
Testing and Fault Isolation	101
Disassembly	301
Cleaning.....	401
Check.....	501
Repair	601
Assembly and Storage	701
Fits and Clearances.....	801
Special Tools, Fixtures, and Equipment.....	901
Illustrated Parts List.....	1001



HTD Aerospace, Inc.

A Triumph Group Company

COMPONENT MAINTENANCE AND OVERHAUL MANUAL
OMP3974

INTRODUCTION

This manual gives overhaul and maintenance instructions with an illustrated parts list for the Retract Actuator, part numbers OMP3974-1 and OMP3974-3. HTD Aerospace, Inc., 29 Industrial Park Road, East Lyme, CT 06333, Telephone (860) 739-4926, makes this retract actuator.

This manual has these sections in it:

- | | |
|---------------------------|-----------------------------|
| - Title Page | - Table of Contents |
| - Record of Revisions | - Introduction |
| - List of Effective Pages | - Procedures & IPL Sections |

Refer to the Table of Contents for the page number of a special section.

Data is given in the introduction of the Illustrated Parts List that tells you how to use it.

All weights and measurements are given in English units. Metric equivalents are given in parentheses, where applicable.

The manual will be revised as necessary to show current data.



DESCRIPTION AND OPERATION

1. Description and Operation.

A. Description.

- (1) The landing gear system uses three retract actuators:
 - one mounts on the nose landing gear
 - one mounts on the left-hand main landing gear
 - one mounts on the right-hand main landing gear.

- (2) The retract actuators operate hydraulically using hydraulic fluid Mil-PRF-5606 at 1500 psi (10341 kPa).

B. Operation.

When you apply hydraulic pressure at the retract port (located on the housing at the opposite end from the piston rod end), the piston head and piston rod move forward. When you apply hydraulic pressure at the extend port, the piston head and piston rod move back in the housing.

2. Leading Particulars.

Weight (Dry, max.) (OMP3974-1)	1.41 pounds (0.640 kg)
Weight (Dry, max.) (OMP3974-3)	1.46 pounds (0.658 kg)
Operating Fluid	MIL-PRF-5606
Operating Fluid Pressure	1500 psi (10341 kPa)
Operating Temperature	-40 to 125 °F (-4.4 to 51.7 °C)
Hydraulic Fluid Operation temperature	-40 to 180 °F (-4.4 to 82.2 °C)
Operating Altitude Range	Sea level to 20,000 feet (6100 meters)



COMPONENT MAINTENANCE AND OVERHAUL MANUAL
OMP3974

TESTING AND FAULT ISOLATION

1. Testing of Retract Actuator.

A. Proof Pressure Test. (See IPL, Figure 1.)

- (1) Apply 2295 psi (15822 kPa) oil pressure (MIL-PRF-5606 at 80 to 120 °F (26.7 to 48.9 °C)) to each port alternately for 2 minutes, with the opposite port open.
- (2) Visually examine the retract actuator for evidence of external leakage, permanent deformation, or malfunction.

B. Operational Test.

- (1) Apply 1500 psi (10341 kPa) oil pressure to each port alternately and operate the retract actuator 25 times.
- (2) There shall be no binding or external static leakage. One drop per seal is the maximum dynamic leakage permitted.
- (3) Check that the piston rod stroke is 3.388 ± 0.070 inches (86.0 \pm 1.8 mm) for OMP3974-1 and 3.263 ± 0.085 inches (82.8 \pm 2.2 mm) for OMP-3974-3.

2. Troubleshooting of Retract Actuator.

Refer to Table 101 and IPL, Figure 1.

Table 101
Troubleshooting

Symptom	Probable Cause	Correction
Too much hydraulic fluid leakage.	Defective packing or backup retainers.	For OMP3974-1, after release of CMM Rev. May 31/05, replace the actuator with OMP3974-3. For OMP3974-3, replace AGT ring seals (32, 47, and 57).



HTD Aerospace, Inc.

A Triumph Group Company

COMPONENT MAINTENANCE AND OVERHAUL MANUAL
OMP3974

DISASSEMBLY

1. General.

Refer to the TESTING AND FAULT ISOLATION section to find the condition of the component or most probable cause of its malfunction. Disassemble the unit only to the extent necessary for cleaning, inspection, fault isolation, or parts replacement.

2. Procedure.

Refer to IPL, Figure 1.

- (1) Remove the retaining ring (5).
- (2) Carefully pull the piston rod assembly (65) and the internal components out of the housing assembly (80).
- (3) Remove the self-locking nut (10).
- (4) For OMP3974-1, remove washer (15) and piston head (20).
- (5) For OMP3974-3, remove washers (15A, qty 3) and piston head (20A).
- (6) For OMP3974-1, remove and discard the two packing backup retainers (25), packing (30), and packing (35) from the piston head (20).
- (7) For OMP3974-3, remove and discard AGT ring seal (32) and packing (35) from the piston head (20A).
- (8) Remove the gland (40 or 40A) from the piston rod assembly (65).
- (9) For OMP3974-1, remove and discard the packing (45), two packing backup retainers (50), and packing (55) from the gland (40).
- (10) For OMP3974-3, remove and discard AGT ring seals (47 and 57) from the gland (40A).
- (11) Remove and discard the scraper (60).
- (12) If damage is shown, remove the bearing (75) from the piston rod (70).
- (13) If damage is shown, remove the bearing (90) and the nameplate (95) from the housing (85).



COMPONENT MAINTENANCE AND OVERHAUL MANUAL
OMP3974

CLEANING

1. Cleaning Materials.

Refer to Table 401 for materials used for cleaning.

Table 401
Cleaning Materials

Nomenclature	Description	Manufacturer/Supplier
Solvent, Dry-Cleaning	P-D-680, Type II	Commercially Available
Cloth, Low-Lint	MIL-C-85043, Type II	Commercially Available
Brush, Soft-Bristled	MIL-B-23958	Commercially Available
Oil, Corrosion-Preventive	MIL-C-8188	Commercially Available
Compound, Corrosion-Preventive	MIL-C-16173, Class 3	Commercially Available
Rust Lick	Rust Lick 606	Rust Lick, Inc. 30-T Endicott St. Danvers, MA

NOTE: Equivalent alternatives may be used.

2. Detail Parts Cleaning.

A. Mechanical Parts.

WARNING: THE USE OF CLEANING SOLVENTS CAN BE A HEALTH HAZARD IF THE PROPER PRECAUTIONS ARE NOT OBEYED. METHODS OF EXPOSURE TO POTENTIAL HEALTH HAZARDS ARE: BREATHING AIR CONTAINING SOLVENT VAPORS, ABSORBING SOLVENTS THROUGH THE SKIN, TOUCHING SOLVENTS DIRECTLY WITH SKIN, AND INGESTION OR SWALLOWING OF SOLVENTS OR SOLVENT RESIDUE. TO LESSEN THE DANGER OF BECOMING EXPOSED TO A POTENTIAL HEALTH HAZARD, BE SURE TO OBEY THE FOLLOWING PRECAUTIONS WHEN WORKING WITH OR AROUND CLEANING SOLVENTS.

- SUPPLY SUFFICIENT VENTILATION TO CARRY OFF THE UNWANTED SOLVENT VAPORS.
- USE A PROTECTIVE MASK, IF NECESSARY FOR SAFE BREATHING.
- USE PROTECTIVE CLOTHING SUCH AS SYNTHETIC RUBBER GLOVES, PLASTIC OR RUBBER BOOTS, APRONS, SLEEVES, OR FACE SHIELDS TO KEEP THE VAPORS AND SOLVENTS FROM SKIN.

IF SUITABLE GLOVES ARE NOT AVAILABLE, USE PROTECTIVE OINTMENTS OR CREAM ON THE HANDS. APPLY TWO TO FOUR TIMES A DAY.



HTD Aerospace, Inc.

A Triumph Group Company

COMPONENT MAINTENANCE AND OVERHAUL MANUAL
OMP3974

- WASH YOUR WORK CLOTHES FREQUENTLY TO PREVENT CONTAMINATION.
- USE ONLY AS MUCH SOLVENT AS IS NECESSARY TO DO THE JOB.
- MAKE USE OF THE LEAST TOXIC SOLVENT POSSIBLE TO DO THE JOB. DRY-CLEANING SOLVENT P-D-680, TYPE II IS THE LEAST TOXIC OF SOLVENTS AND SHOULD BE USED WHERE HEAVY DEPOSITS OF OIL AND GREASE REQUIRE THE USE OF CLEANING MATERIALS IN LARGE QUANTITIES.

- (1) Clean all metal components with a lint-free cloth moist with dry-cleaning solvent.
- (2) Use a stiff brush soaked in dry-cleaning solvent to loosen any unwanted material.

WARNINGS: PROTECT YOUR EYES WHEN USING COMPRESSED AIR.

- (3) After all chips, grease, and dirt are removed, dry the components with clean filtered compressed air at 20 to 60 psi (137.8 to 413.6 kPa).
- (4) Check all the hydraulic fluid passages in the housings and detail parts to be open to flow and free of obstructions. Flush all the passages in both directions with dry-cleaning solvent under pressure.

B. Parts Protection.

Apply a protective layer to all steel parts if the reassembly of parts is not to be conducted immediately after their cleaning. Do this with the corrosion-preventive oil MIL-C-8188, corrosion-preventive compound MIL-C-16173 Class 3, or Rust Lick 606.



COMPONENT MAINTENANCE AND OVERHAUL MANUAL
OMP3974

CHECK

1. General.

A. Testing.

CHECK starts with testing and troubleshooting. Testing inspections, such as checks for leakage and correct fit and movement, are given in the TESTING AND FAULT ISOLATION section.

B. Fits and Clearances.

The FITS AND CLEARANCES section gives the manufacturing and service limits of the parts used in the retract actuator. All parts given should be examined for unusual wear or damage and for correct limits; those parts more than their limits are to be tagged for replacement.

2. Inspection of Detail Parts.

Carefully check the condition of each disassembled part. Reject any part that appears defective and replace any rejected part with a new part. Refer to Table 501 and IPL, Figure 1 and examine parts for the following:

- (1) Inspect the parts with internal and external threads for defective threads.
- (2) Inspect the parts for any distortion and corrosion.
- (3) Inspect all the steel parts given in Table 501. Do this by the indicated method of magnetic particle inspection per ASTM E1444. Inspect the part for fatigue cracks, heat cracks, and porosity. Inclusions, porosity, and casting flaws are acceptable provided they have not led to excessive corrosion or cracks.
- (4) Demagnetize all parts as completely as possible after inspection. Then check for residual magnetism with a compass. Withdraw the large parts from the demagnetizing coil slowly while turning.
- (5) Use the fluorescent penetrant method to check for any surface defects. Do this per ASTM E1417. When inspecting parts listed in Table 501, inspect part for fatigue cracks, heat cracks, and porosity.

Table 501
Detail Parts Inspection

Part	Inspect for	Method
Retaining Ring (5)	Distortion, cracks, and chips	Visual and Fluorescent
Self-locking Nut (10)	Distortion, cracks, chips, and damaged threads	Visual
Piston Head (20 or 20A)	Distortion, cracks, and chips	Visual and Magnaflux
Gland (40) or (40A)	Distortion, cracks, and chips	Visual and Fluorescent



HTD Aerospace, Inc.

A Triumph Group Company

COMPONENT MAINTENANCE AND OVERHAUL MANUAL
OMP3974

Table 501 (Cont)
Detail Parts Inspection

Part	Inspect for	Method
Piston Rod (70)	Distortion, cracks, chips, damaged threads and wear	Visual and Magnaflux
Bearing (75)	Wear, distortion, cracks, chips, and play in the ball	Visual
Housing (85)	Scratches, cracks, chips, and wear	Visual and Fluorescent
Bearing (90)	Wear, distortion, cracks, chips, and play in the ball	Visual



COMPONENT MAINTENANCE AND OVERHAUL MANUAL
OMP3974

REPAIR

1. General.

Except as noted below, do not attempt repair of any defective part. Replace any part found to be defective or outside of the required tolerance. Refer to Illustrated Parts List for information on how to requisition new parts. For procedures on upgrading OMP3974-1 to OMP3974-3, refer to paragraph 4.

2. Repair Materials.

Refer to Table 601 for the materials used for repair.

Table 601
Repair Materials

Nomenclature	Description	Manufacturer/Supplier
4/0 Crocus Cloth	P-C-458C	Commercially Available
Alodine No. 1200	MIL-C-5541C	Commercially Available
Brush, Soft-Bristled	MIL-B-23958	Commercially Available
Staking Tool	T2681903-1	HTD Aerospace, Inc.
Zinc Chromate	MIL-P-8585	Commercially Available
Petrolatum	MIL-C-11796	Commercially Available

NOTE: Equivalent alternatives may be used.

3. Repair Procedures.

A. Damaged or Worn Parts.

Repair of the retract actuator is made by the replacement of the defective part or parts.

B. Nicks, Scratches, and Blemishes (see IPL, Figure 1).

- (1) Repair minor nicks and scratches on noncritical external surfaces using crocus cloth per Federal Specification P-C-458. The sealing surfaces of the gland (40 or 40A), piston rod (70) and housing (85) may be polished to a depth of .002 inch (0.051 mm) maximum (chrome plated) surface of piston .001 inch (0.025 mm) maximum to remove surface defects.

CAUTION: REPLACE THE PISTON IF ANY POLISHED AREA ON CHROME PLATED SURFACE BREAKS THROUGH THE PLATING.

- (2) After the repair has been accomplished, clean the items per the CLEANING section.
- (3) Use a brush and apply alodine to repaired aluminum surfaces. Use a brush and cadmium plate required steel surfaces that are not chromate plated. Do not cadmium plate surfaces touching hydraulic fluid.



HTD Aerospace, Inc.

A Triumph Group Company

COMPONENT MAINTENANCE AND OVERHAUL MANUAL
OMP3974

- C. Roller Staking of Bearings. Roller stake bearings as shown in Figure 601 using special staking tool number T2681903-1.

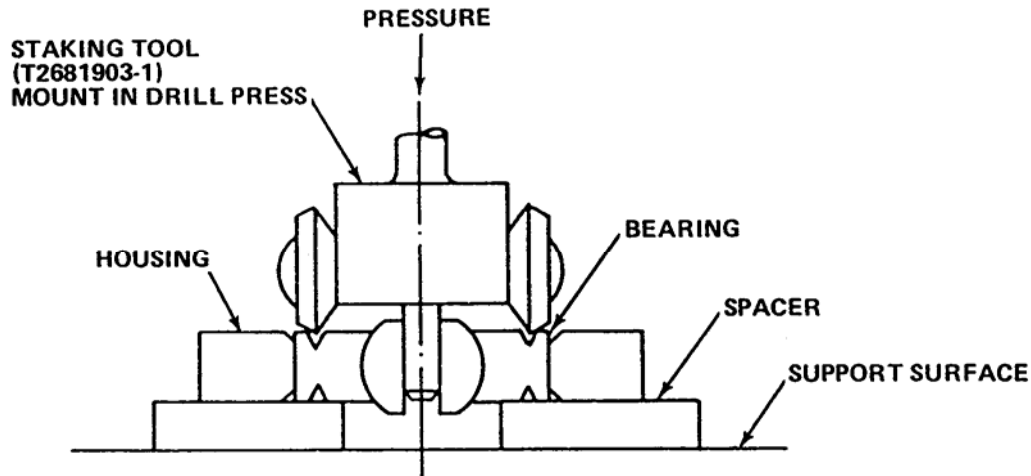

Roller Staking Setup
Figure 601

- (1) Wet the mating surfaces with MIL-P-8585 primer. Then put the bearing in the housing.
- (2) Apply petrolatum to the groove in the bearing and the staking rollers.

CAUTION: DO NOT ALLOW THE PETROLATUM TO GET ON BALL OR EXPOSED EDGE OF LINER. ANY PETROLATUM ON THESE SURFACES MUST BE MADE CLEAN IMMEDIATELY.

- (3) Start the drill press rotating at 100-150 rpm. Then apply sufficient pressure to swage outer lip of bearing over the chamfer in housing. The pressure must not be applied for periods longer than 15 seconds. Do not allow staking rollers to contact ball side of groove as binding of ball may result.
- (4) Turn the assembly over and do the staking procedure again.

4. Upgrade of OMP3974-1 to OMP3974-3.

A. Replacement Parts.

Refer to Table 602 for the replacement parts for upgrade of OMP3974-1 to OMP3974-3.

COMPONENT MAINTENANCE AND OVERHAUL MANUAL
OMP3974

Table 602
Replacement Parts for Upgrade

OMP3974-1 (Discard these items)	OMP3974-3 (Replace with these items)
Washer (15) Piston Head (20) Packing, Backups (25) (Qty of 2) Packing (30) Gland (40) Packing (45) Packing, Backups (50) (Qty of 2) Packing (55)	Washers (15A) (Qty of 3) Piston Head (20A) AGT Ring Seal (32) Gland (40A) AGT Ring Seal (47) AGT Ring Seal (57)

B. Inspection.

- (1) Inspect housing (85) bore ID as described in Table 801. Also, inspect for local deep wear marks near the entrance to the bore where piston head (20) made contact. If the locally concentrated depth is greater than 0.002 inches, then replace the housing. If the locally concentrated depth is between 0.0005 inches and 0.002 inches, then rework the housing as described in paragraph 5. If the locally concentrated depth is less than 0.0005 inches, then no repairs are necessary.
- (2) Inspect piston rod (70) OD as described in Table 801. Also, inspect for local deep wear marks near the threaded end of the OD where the gland (40) made contact. If there are scratches or scarring greater than 0.0005 inches deep on the .496/.498 OD, then rework the piston as described in paragraph 5. If there are no scratches, then no repairs are necessary.

5. Rework Repair of Housing (85) and Piston Rod (70).

A. Rework Repair of Housing (85).

- (1) Machine the housing bore ID to a maximum diameter of 1.434 inches.
- (2) Electrolyze the bore ID per MIL-DTL-23422, AMS2406 or AMS2438.
- (3) Finish dimensions to original manufacturing limits described in Table 801 and maintain surface finish of 16 rms or better.

B. Rework Repair of piston rod (70).

- (1) Machine the rod OD to a minimum diameter of 0.488 inches to remove chrome plating.
- (2) Chrome plate the rod OD per AMS-QQ-C-320 (hard chrome).
- (3) Finish dimensions to original manufacturing limits described in Table 801 and maintain a surface finish of 16 rms or better.



COMPONENT MAINTENANCE AND OVERHAUL MANUAL
OMP3974

ASSEMBLY

1. Assembly of Retract Actuator.

A. General.

- (1) Make sure all parts are fully free of chips, grease, or dirt.
- (2) Use only defect-free packings and prevent damage to them during assembly.
- (3) Put the packings fully into the hydraulic fluid MIL-PRF-5606 before you install them.

B. Materials.

Table 701 gives the tools, equipment, and materials necessary to assemble the retract actuator.

Table 701
Tools, Equipment and Materials

Nomenclature	Part No.	Source
Hydraulic Fluid	MIL-PRF-5606	Commercially Available
Adhesive	EC1751	3M Company 3M Center Saint Paul, Minnesota 55144-1000
Zinc Chromate	MIL-P-8585	Commercially Available
Oil Corrosion-Preventive	MIL-C-8188	Commercially Available
Compound, Corrosion-Preventive	MIL-C-16173, Class 3	Commercially Available
Rust Lick	Rust Lick 606	Rust Lick, Inc. 30-T Endicott St. Danvers, MA

NOTE: Equivalent alternatives may be used.

2. Procedure.

Refer to IPL, Figure 1.

- (1) If removed, install a new bearing (90) in the housing (85), and a new bearing (75) in the piston rod (70). Roller stake the new bearings using tool number T2681903-1. Refer to REPAIR paragraph 3.C.

NOTE: Wet the dissimilar metal mating surfaces with the zinc chromate primer MIL-P-8585 before installing the bearings (75 and 90).

- (2) For OMP3974-1, install a new scraper (60), two new packing backup retainers (50), new packing (55), and new packing (45) on the gland (40).



HTD Aerospace, Inc.

A Triumph Group Company

COMPONENT MAINTENANCE AND OVERHAUL MANUAL
OMP3974

- (3) For OMP3974-3, install new scraper (60), and install new AGT ring seals (47 and 57) on the gland (40A).
- (4) Carefully move the gland (40 or 40A) onto the piston rod assembly (65).
- (5) For OMP3974-1, install a new packing (35), two new packing backup retainers (25), and new packing (30) on the piston head (20).
- (6) For OMP3974-3, install new packing (35), and install new AGT ring seal (32) on the piston head (20A).
- (7) Carefully move the piston head (20 or 20A) onto the piston rod assembly (65).
- (8) Install the washer (15 for OMP3974-1 or 15A (qty of 3) for OMP3974-3) and self-locking nut (10) on the piston rod assembly (65). Then tighten the self-locking nut (10) to 100-140 pound-inches (11.3-15.8 N•m) for OMP3974-1 and 150-180 pound-inches (16.9-20.3 N•m) for OMP3974-3.
- (9) Carefully move the piston rod assembly (65) and the internal components into the housing assembly (80). Then install the retaining ring (5).
- (10) If removed, attach the nameplate (95) to the housing assembly (80) with the adhesive EC1751.
- (11) Perform the Proof Pressure and Operational Test given in the TESTING AND FAULT ISOLATION section of this manual.

3. Storage After Assembly.

Apply a protective layer to all steel surfaces if the retract actuator reinstallation is not to be performed after assembly. Do this with the corrosion-preventive oil MIL-C-8188, corrosion-preventive compound MIL-C-16173 class 3, or Rust Lick 606.

COMPONENT MAINTENANCE AND OVERHAUL MANUAL
OMP3974

FITS AND CLEARANCES

1. Fits and Clearances.

Refer to Table 801 and IPL, Figure 1.

Table 801
Fits and Clearances

Mating IPL Figure and Item No.	Original Mfg Limits				In-Service Wear Limits		
	Dimension (inches) (millimeters)		Assembly Clearance inches (millimeters)		Dimension Limits inches (millimeters)		Max Allowable Clearance inches (millimeters)
	Min	Max	Min	Max	Min	Max	
ID 1-85	1.428 (36.27)	1.430 (36.32)	0.002 (0.051)	0.005 (0.127)	1.428 (36.27)	1.432 (36.37)	0.002-0.009 (0.051-0.229)
OD 1-20 1-20A	1.425 (36.20)	1.426 (36.22)			1.423 (36.14)	1.426 (36.22)	
ID 1-40 1-40A	0.500 (12.7)	0.501 (12.73)	0.002 (0.051)	0.005 (0.127)	0.500 (12.7)	0.503 (12.78)	0.002-0.008 (0.051-0.203)
OD 1-70	0.496 (12.60)	0.498 (12.65)			0.495 (12.57)	0.498 (12.65)	
ID 1-75	0.3120 (7.93)	0.3125 (7.94)			0.3120 (7.93)	0.3130 (7.95)	
ID 1-90	0.3120 (7.93)	0.3125 (7.94)			0.3120 (7.93)	0.3130 (7.95)	

2. Torque Values.

Refer to Table 802 and IPL, Figure 1.

Table 802
Torque Values

IPL Fig. and Item No.	Item	Torque (Newton Meters)
1-10	Self-Locking Nut	100-140 pound-inches (11.3-15.8) for OMP3974-1 150-180 pound-inches (16.9-20.3) for OMP3974-3.



HTD Aerospace, Inc.

A Triumph Group Company

COMPONENT MAINTENANCE AND OVERHAUL MANUAL
OMP3974

SPECIAL TOOLS, FIXTURES, AND EQUIPMENT

Table 901 shows the special tools, fixtures, and equipment that are necessary.

Table 901
Special Tools, Fixtures, and Equipment

Nomenclature	Description	Manufacturer/Supplier
Staking Tool	T2681903-1	HTD Aerospace, Inc.

NOTE: Equivalent substitutes may be used.



COMPONENT MAINTENANCE AND OVERHAUL MANUAL
OMP3974

ILLUSTRATED PARTS LIST

1. Purpose.

This section provides illustrations and parts breakdown of all parts of the retract actuator shown on the title page which can be:

- Disassembled
- Repaired or replaced
- Reassembled.

2. Explanation and Usage of Section.

A. Assembly Order Indenture System.

- (1) The indenture system used in the parts list shows the relationship of one part to another. For a given item, the number of indentures shows the relationship of the item to the related next higher assembly, as follows:

1 2 3

Assembly

Detail Parts for Assembly

Subassembly

Attaching Parts for Subassembly

Detail Parts for Subassembly

Detail Installation Parts for Assembly (included only if the installation parts can be sent to the shop as part of the assembly).

- (2) Attaching parts are listed immediately following and at the same indentation as the item that they attach. They are captioned (ATTACHING PARTS) and the symbol *** separates them from subsequent listed parts or subassemblies.
- (3) All parts of the equipment are shown except parts which lose their identity by being welded, or otherwise permanently fastened to other parts or assemblies and are not subject to disassembly.

B. Part Number System.

When a supplier's part number is listed in the part number column, a manufacturer's code is shown in the nomenclature column. The supplier's specification control drawing is listed (after the nomenclature) for all suppliers items covered by these drawings. There is no code listing for government standard parts (MS, NAS, etc.).

C. Usable On Code.

A letter (A, B, C, etc.) for each top assembly is given in the USABLE ON CODE column. The letter of the applicable top assembly is also shown in the USABLE ON CODE column for each detail part and subassembly. But, no letter is shown in the USABLE ON CODE column if the detail parts and subassemblies are the same for all the top assemblies.



COMPONENT MAINTENANCE AND OVERHAUL MANUAL
OMP3974

D. Units Per Assembly.

- (1) The UNITS PER ASSY column shows the total number of units that are necessary for each:
 - Assembly, as applicable
 - Subassembly, as applicable
 - Sub-subassembly, as applicable.
- (2) For bulk items, the letters AR show that the quantity for each assembly is "as required".
- (3) The letters RF show that the item is given to use as a reference.

E. Parts Replacement Data.

Parts replacement data and the interchangeable relation between the parts is given in the NOMENCLATURE column. The words used to show this data, their abbreviations, and their definitions are as follows:

<u>Term</u>	<u>Parts List Abbreviations</u>	<u>Definition</u>
Optional	OPT	This part is optional to and interchangeable with other parts in the same item number variant group, or other item number if designated.
Superseded by	SUPSD BY	The part in the part number column is replaced by and is not interchangeable with the item number shown in the note.
Supersedes	SUPSDS	The part in the part number column replaces and is not interchangeable with the item number shown in the note.
Replaced by	REPLD BY	The part in the part number column is replaced by and interchangeable with the item number shown in the note.
Replaces	REPLS	The part in the part number column replaces and is interchangeable with the item number shown in the note.

F. Service Bulletin Incorporation.

- (1) Unless shown below, assemblies (and subassemblies and detail parts) for which change, deletion, addition, or replacement is probable by an issued service bulletin, are written to show:
 - The configuration before the service bulletin.



COMPONENT MAINTENANCE AND OVERHAUL MANUAL
OMP3974

- The configuration after the service bulletin.

(PRE SB XXXX) in the NOMENCLATURE column shows the initial configuration. (POST SB XXXX) shows assemblies and parts after the service bulletin change has been completed.

- (2) Subassemblies and detail parts used on assemblies that have the (PRE SB XXXX) or the (POST SB XXX) note, will not have the same note themselves, if the effectivity code(s) given to them clearly show(s) if they are used before the service bulletin or after the service bulletin.
- (3) Top assemblies that are likely to change by a service bulletin and that have not been given a new part number (no production equivalent of the changed assembly) are not shown with before service bulletin or after service bulletin data.
- (4) If a subassembly or detail part is changed by a service bulletin and a new part number is not given, the initial part number is given with an alpha-variant item number and (POST SB XXXX). The effectivity code stays the same as for the configuration before the service bulletin.

G. Items Not Illustrated.

Items which are not illustrated are shown with a dash (-) written in front of the item number in the FIG & ITEM NO. column.

H. Alpha-Variant Item Numbers.

- (1) Alpha-variants A-Z (but not I and O) are given to an item number already in use, when necessary to show:
 - (a) Added items
 - (b) Service bulletin modifications
 - (c) Configuration differences
 - (d) Optional parts
 - (e) Product improvement parts (non-service bulletin).
- (2) Alpha-variant item numbers are not shown on the exploded view when the appearance and location of the alpha-variant item is the same as the basic item.

I. Vendor Codes (CAGE).

The following list is a compilation of the vendor codes with the name and addresses of suppliers for purchased parts used in this illustrated parts list.



HTD Aerospace, Inc.

A Triumph Group Company

COMPONENT MAINTENANCE AND OVERHAUL MANUAL
OMP3974

<u>Vendor Code</u>	<u>Manufacturer's Name and Address</u>
33068	HTD Aerospace, Inc. 29 Industrial Park Road East Lyme, CT 06333
5F573	Greene Tweed and Co., Inc. 2075 Detwiler Road P.O. Box 305 Kulpsville, PA 19443-0305
80756	TRW, Inc. Ramsey Corp. 1233 Manchester Road P.O. Box 513 St. Louis, MO 63011-4511
97820	W.S. Shamban and Co. 711 Mitchell Road P.O. Box 665 Newbury Park, CA 91320-2214



HTD Aerospace, Inc.

A Triumph Group Company

COMPONENT MAINTENANCE AND OVERHAUL MANUAL
OMP3974

This page intentionally left blank.



HTD Aerospace, Inc.

A Triumph Group Company

COMPONENT MAINTENANCE AND OVERHAUL MANUAL
OMP3974

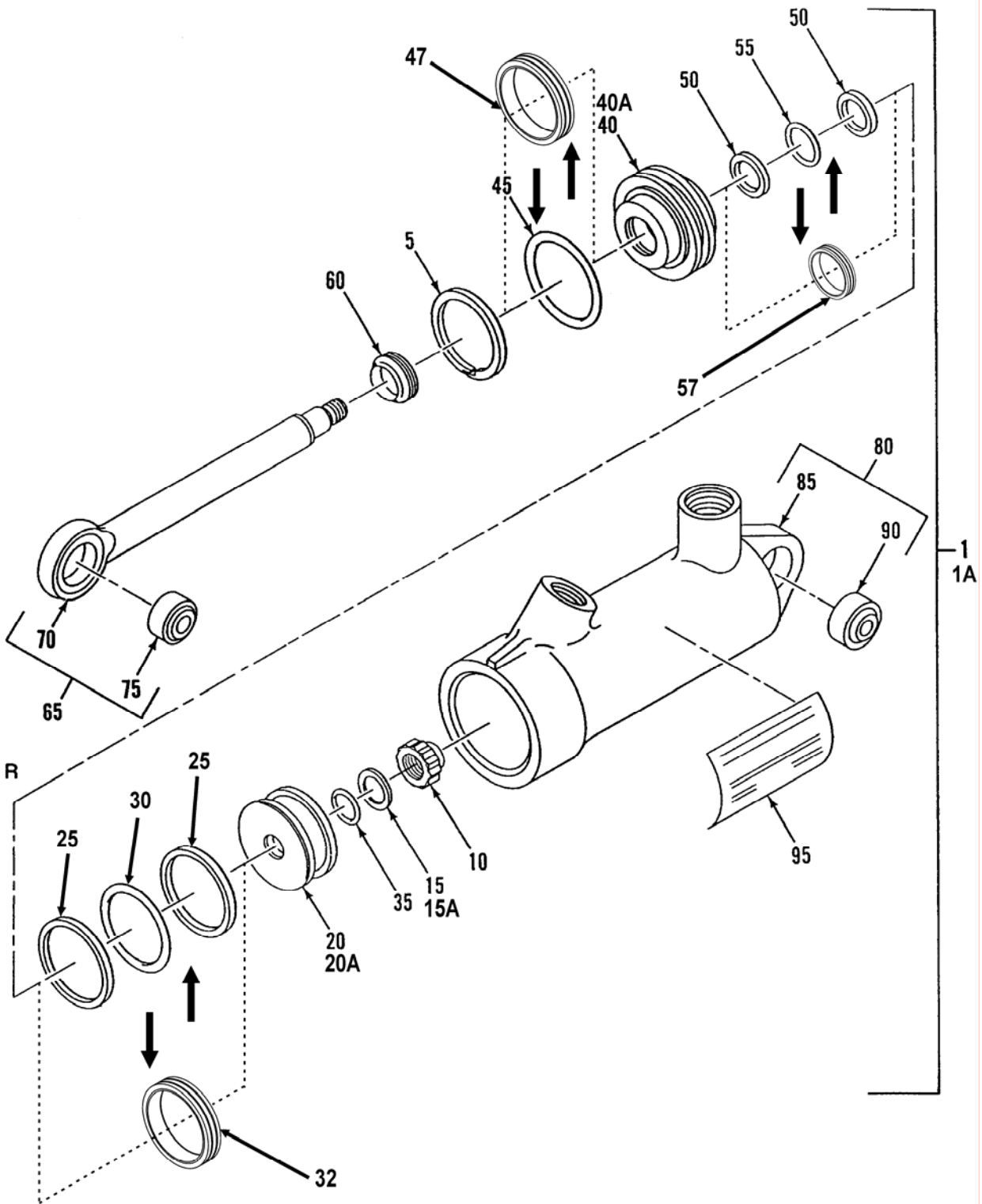

Retract Actuator
Figure 1



HTD Aerospace, Inc.

A Triumph Group Company

COMPONENT MAINTENANCE AND OVERHAUL MANUAL
OMP3974

FIGURE & ITEM NUMBER	PART NUMBER	AIRLINE PART NUMBER	NOMENCLATURE 1 2 3 4 5 6 7	USABLE ON CODE	UNITS PER ASSY
1-					
1	OMP3974-1		ACTUATOR, RETRACT	A	1
1A	OMP3974-3		ACTUATOR, RETRACT	B	1
5	RRN-156C		. RING, RETAINING (V80756)		1
10	ES192-5		. NUT, SELF-LOCKING (V33068)		1
15	AN960-616L		. WASHER	A	1
15A	MS21206-6		. WASHER	B	3
20	3974003-1		. PISTON HEAD	A	1
20A	3974003-3		. PISTON HEAD	B	1
25	MS28774-217		. RETAINER, PACKING BACKUP	A	2
30	MS28775-217		. PACKING	A	1
32	7217MT-964-P4		. SEAL, GT AGT RING (V5F573)	B	1
35	MS28775-110		. PACKING		1
40	3974004-1		. GLAND	A	1
40A	3974004-3		. GLAND	B	1
45	MS28775-126		. PACKING	A	1
47	7126MR-964-T		. SEAL, GT AGT RING (V5F573)	B	1
50	MS28774-112		. RETAINER, PACKING BACKUP	A	2
55	MS28775-112		. PACKING	A	1
57	7112FT-964-P4		. SEAL, GT AGT RING (V5F573)	B	1
60	S11065-1-1		. SCRAPER (V97820)		1
65	3974002-1		. PISTON ROD ASSY		1
70	3974002-11		. . PISTON ROD		*1
75	MS14101-5		. . BEARING		1
80	3974001-1		. HOUSING ASSY		1
85	3974001-11		. . HOUSING		*1
90	MS14101-5		. . BEARING		1
95	3974100-1		. NAMEPLATE		1

*Not procurable