



A Textron Company

## **TECHNICAL BULLETIN**

**206-19-211**

29 August 2023

**MODEL AFFECTED:** 206A/B and TH-67

**SUBJECT:** FUEL FILTER ASSEMBLY 222-366-621-103,  
UPGRADE OF.

**HELICOPTERS AFFECTED:** Serial numbers 4 through 4690 and 5101 through  
5313.

**COMPLIANCE:** At customer's option.

### **DESCRIPTION:**

Bell has received reports of reliability issues (leaks and deficiencies) with the impending bypass test switch on the head assembly of the airframe mounted fuel filter assembly 222-366-621-103. This Technical Bulletin (TB) allows operators to either replace the 222-366-621-103 fuel filter assembly with the 222-366-621-105 fuel filter assembly or modify the -103 fuel filter assembly to the -105 configuration by replacing the head assembly 1744990 with the new head assembly 2177100-30. The -103 and the -105 fuel filter assemblies have no difference in their fit, form, or function. The new head assembly has a data plate attached to it, which includes the fuel filter assembly part number 222-366-621-105 and a serial number. When the head assembly is ordered separately, the serial number on the data plate has a suffix "S", which identifies the fuel filter assembly 222-366-621-105 being field modified per this TB. When the entire fuel filter assembly 222-366-621-105 is ordered, the serial number suffix "S" is omitted from the data plate.

The fuel filter assembly 222-366-621-105 replaces the -001, -003, -101 and -103 fuel filter assemblies as spare part.

Applicability of this bulletin to any spare part shall be determined prior to its installation on an affected helicopter.

**APPROVAL:**

The engineering design aspects of this bulletin are Transport Canada Civil Aviation (TCCA) approved.

**CONTACT INFO:**

For any questions regarding this bulletin, please contact:

Bell Product Support Engineering  
Tel: 1-450-437-2862 / 1-800-363-8023 / productsupport@bellflight.com

**MANPOWER:**

Approximately 1.5 man-hours are required to complete this bulletin. This estimate is based on hands-on time and may vary with personnel and facilities available.

**WARRANTY:**

There is no warranty credit applicable for parts or labor associated with this bulletin.

**MATERIAL:****Required Material:**

The following material is required for the accomplishment of this bulletin and may be obtained through your Bell Supply Center.

<u>Part Number</u>	<u>Nomenclature</u>	<u>Qty (Note)</u>
222-366-621-105	Fuel Filter Assembly	1 (1, 3)
2177100-30	Head Assembly	1 (2, 4)
1743645-03	Fuel Filter Kit	1 (2, 5)
MS29512-04	Packing	1 (1, 2)
MS29512-12	Packing	2 (1, 2)
222-366-644-001	Seal	2 (6)
MS29513-238	Packing	1 (6)

**NOTES:**

1. To be ordered when replacing the 222-366-621-001, -003, -101 or -103 fuel filter assembly with the -105 fuel filter assembly.
2. To be ordered when modifying the 222-366-621-103 fuel filter assembly to the -105 configuration and replacing the filter element at the same time.
3. Replaces the 222-366-621-103 fuel filter assembly.
4. Sub part of the fuel filter assembly 222-366-621-105.
5. The fuel filter kit 1743645-03 consists of fuel filter element 222-366-643-001 (Qty 1), seal 222-366-644-001 (Qty 2) and packing MS29513-238 (Qty 1).

6. Item to be ordered in place of fuel filter kit 1743645-03 when modifying the 222-366-621-103 fuel filter assembly to the -105 configuration without filter element replacement.

**Consumable Material:**

The following material is required to accomplish this bulletin, but may not require ordering, depending on the operator’s consumable material stock levels.

This material may be obtained through your Bell Supply Center.

<u>Part Number</u>	<u>Nomenclature</u>	<u>Qty (Note)</u>	<u>Reference *</u>
Commercial	Caps or Plugs	A/R	C-156
Commercial	Caps or Plugs	A/R	C-428
Commercial	Turbine Fuel	A/R	C-003
2010-00088-00	Sealant	2 OZ (1)	C-308
1650-03296-00	Safety Wire (0.032”)	1 ROLL (1)	C-405

\* C-XXX numbers refer to the consumables list in the BHT-ALL-SPM, Standard Practices Manual

**NOTE 1:** The quantity indicated is the format the product is delivered in. Actual quantity required to accomplish the instructions in this bulletin may be less.

**SPECIAL TOOLS:**

None required.

**WEIGHT AND BALANCE:**

Not affected.

**ELECTRICAL LOAD DATA:**

Not affected.

**REFERENCES:**

BHT-206A/B-SERIES-MM  
206-SI-65

**PUBLICATIONS AFFECTED:**

BHT-206A/B-SERIES-IPB

## ACCOMPLISHMENT INSTRUCTIONS:

-NOTE-

To minimize the downtime and the associated costs, this Technical Bulletin could be accomplished in conjunction with the fuel filter element servicing requirements (BHT-206A/B-SERIES-MM, Chapter 12).

1. Prepare the helicopter for maintenance.

-NOTE-

On early Model 206As and 206Bs the airframe mounted fuel filter was an auxiliary equipment kit per Service Instruction 206-65.

2. Remove the fuel filter assembly 222-366-621-001, -003, -101 or -103 (BHT-206A/B-SERIES-MM, Chapter 28).

-NOTE-

Carry out step 3 through 5 only if you are modifying the 222-366-621-103 fuel filter assembly to the -105 configuration. Otherwise, go to step 6.

3. Remove the head assembly from the fuel filter assembly 222-366-621-103 (BHT-206A/B-SERIES-MM, Chapter 28).

-NOTE-

Replacement of the fuel filter element is not required if it is serviceable. The fuel filter element can be replaced at this time as a convenience or it can be replaced at the next scheduled servicing interval (BHT-206A/B-SERIES-MM, Chapter 12).

4. If found not serviceable, replace the fuel filter element (4, Figure 2) (BHT-206A/B-SERIES-MM, Chapter 28).
5. Install the new fuel filter head assembly 2177100-30 (Figure 1) (BHT-206A/B-SERIES-MM, Chapter 28). Torque the filter bowl to the head assembly at  $130\pm 20$  inch-pounds ( $14.7\pm 2.3$  Nm).
6. Install the fuel filter assembly 222-366-621-105 (BHT-206A/B-SERIES-MM, Chapter 28).
7. Make an entry in the helicopter logbook and historical service records indicating compliance with this Technical Bulletin.

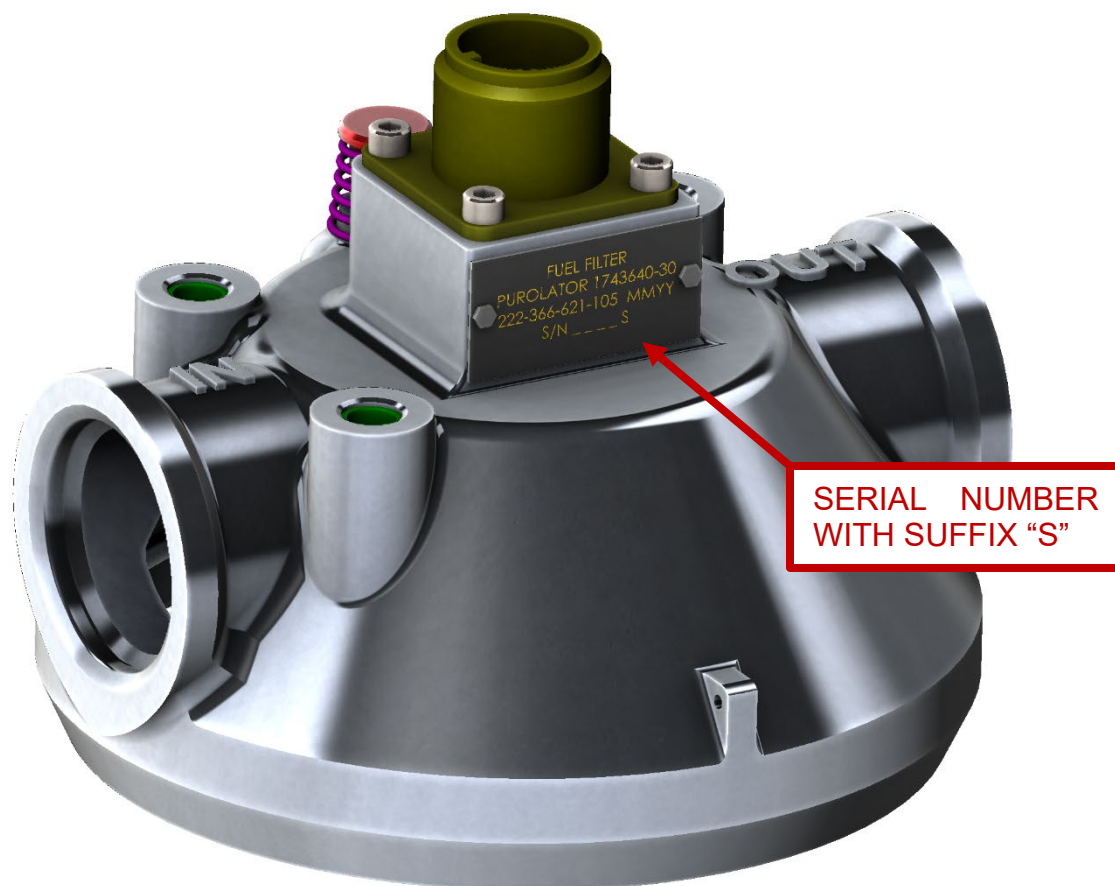

**Figure 1 - Fuel Filter Head Assembly 2177100-30**

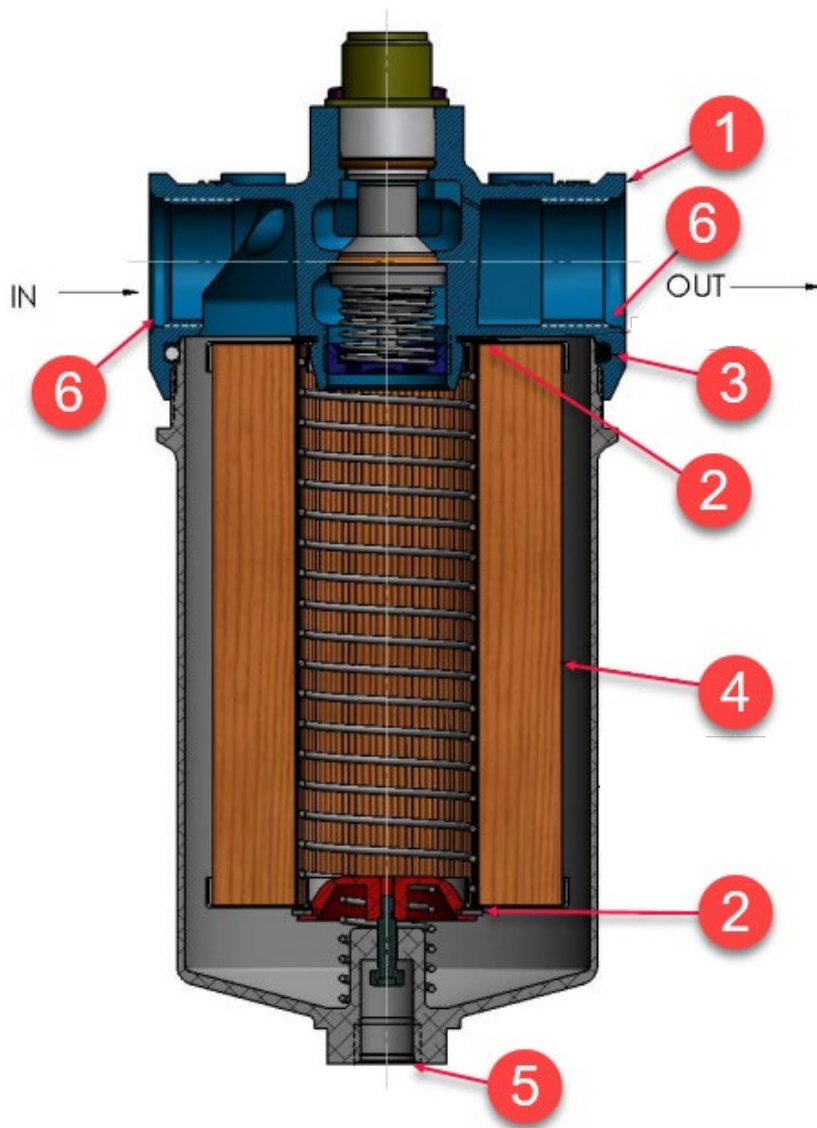

1. Head Assembly 2177100-30
2. Seal 222-366-644-001
3. Packing MS29513-238
4. Element Assembly 222-366-643-001
5. Packing MS29512-04
6. Packing MS29512-12

**Figure 2 - Fuel Filter Assembly 222-366-621-105**