

**TECHNICAL BULLETIN**

**206-16-209**

7 February 2018

**MODEL AFFECTED:** 206A/B and TH-67

**SUBJECT:** CHEM-MILLED BATTERY DOOR AND PIANO HINGE ASSEMBLY 206-033-177-135S, RETROFIT OF

**HELICOPTERS AFFECTED:** Serial numbers as listed in Table 1.

**COMPLIANCE:** At customer's option.

**DESCRIPTION:**

Bell Helicopter has received field reports of cracked plastic hinges on the sheet metal battery door. This bulletin gives instructions on how to retrofit the affected helicopters with an improved chem-milled battery door and piano hinge assembly. **PART I** of this bulletin provides instructions to install the chem-milled battery door and piano hinge assembly. **PART II** of this bulletin provides instructions to install a V-shaped door seal to match the chem-milled battery door and piano hinge assembly.

**APPROVAL:**

The engineering design aspects of this bulletin are Transport Canada Civil Aviation (TCCA) approved.

**CONTACT INFO:**

For any questions regarding this bulletin, please contact:

Bell Helicopter Product Support Engineering - Light Helicopters  
Tel: 450-437-2862 / 1-800-363-8023 / pselight@bh.com

**MANPOWER:**

Approximately 10 man-hours are required to complete this bulletin. This estimate is based on hands-on time and may vary with personnel and facilities available.

**WARRANTY:**

There is no warranty credit applicable for parts or labor associated with this bulletin.

**MATERIAL:****Required Material:**

The following material is required for the accomplishment of this bulletin and may be obtained through your Bell Helicopter Textron Supply Center.

<u>Part Number</u>	<u>Nomenclature</u>	<u>Qty</u>
120-098-05C79	Shim	1
120-098-05D06	Shim	2
20-042-10-5	Radius block	2
20-090-3	Bushing	2
206-031-210-083S	Angle	A/R
206-031-478-203	Seal	1 (Note 2)
206-033-177-123S	Support	1
206-033-177-125	Clip	2
206-033-177-135S	Battery door assembly	1
206-033-180-101	Spacer	1
30-033-22-8C	Cable	2
MS20426AD4-5	Rivet	4 (Note1)
MS20470AD4-4	Rivet	2 (Note 1)
MS20470AD4-6	Rivet	10 (Note 1)
MS21042L3	Nut	2
NAS1149D0322J	Washer	4

**Notes:**

1. Length of rivets may vary from one helicopter to another. The correct length of rivets must be determined at installation.
2. As an alternate, use 5 feet of the 2330-06087-00 (RUBBER-110-161-1B) which is sold by foot length.

**Consumable Material:**

The following material is required to accomplish this bulletin, but may not require ordering, depending on the operator's consumable material stock levels. This material may be obtained through your Bell Helicopter Textron Supply Center.

<u>Part Number</u>	<u>Nomenclature</u>	<u>Qty</u>	<u>Reference *</u>
2010-05988-00	Sealant	1	C-251
2000-00974-00	Adhesive	1	C-317
2000-06013-00	Adhesive	1	C-300

\* C-XXX numbers refer to the consumables list in BHT-ALL-SPM Standard Practices Manual

**SPECIAL TOOLS:**

None required.

**WEIGHT AND BALANCE:**

Not affected.

**ELECTRICAL LOAD DATA:**

Not affected.

**REFERENCES:**

BHT-206A/B-SERIES-MM, Maintenance Manual  
BHT-ALL-SRM, Structural Repair Manual  
BHT-ALL SPM, Standard Practice Manual

**PUBLICATIONS AFFECTED:**

BHT-206A/B-SERIES IPB, Illustrated Parts Breakdown

**ACCOMPLISHMENT INSTRUCTIONS:****PART I: Installation of Battery Door Assembly 206-033-177-135S**

1. Prepare helicopter for maintenance.
2. Gain access to the battery compartment and remove the battery (BHT-206A/B-SERIES-MM, Chapter 96).
3. Remove the washer (1, Figure 1) and the pin (2) from the bracket (3).
4. Drill and remove all the rivets (12) that secure the angle (4), sheet metal battery door (5), and plastic hinge (6).
5. Break the layer of sealant between the mating parts with a warm thin blade putty knife. Be careful not to damage adjacent structural parts.
6. Remove and discard the old sheet metal battery door (5) and the plastic hinge (6).
7. Clean sealant residue from the nose structure.
8. Fit and nest the angle (4), spacer (7), battery door assembly (8), shims (9 and 10), and support (11) at the location shown (Figure 1, Detail B, Sections D-D and E-E).
9. Backdrill the existing holes from the nose structure and the angle (4) to the spacer (7), battery door assembly (8), shims (9 and 10), and support (11).

10. Remove the angle (4), spacer (7), battery door assembly (8), shims (9 and 10), and support (11). Deburr all holes.
11. Coat the faying surfaces between the angle (4), spacer (7), battery door assembly (8), shims (9 and 10), and support (11) with sealant (C-251). Install in the nose structure with wet installed rivets (12) using sealant (C-251).
12. Make sure that no voids or gaps exist after installation. If gaps exist, touch up with sealant (C-251).
13. Place both clips (13), with the outer bend radius facing inboard of the center line of the battery door assembly (8), at the location shown (Figure 1, Section D-D, View F).
14. Drill all holes for the rivets (14) in the battery door assembly (8) and in the clips (13) at the location shown (Figure 1, View F).
15. Remove the clips (13) and deburr all holes.
16. Coat the faying surfaces between the battery door assembly (8) and the clips (13) with sealant (C-251). Install the clips on the battery door assembly with wet installed rivets (14) using sealant (C-251).
17. Drill the stud holes (15) on the battery door assembly (8) using the sheet metal battery door (5) as a template.
18. Install the studs, previously removed from the sheet metal battery door (5), to the battery door assembly (8).
19. Close the battery door assembly (8) and check for interference with the nose structure. If interference exists, trim the edge contour of the battery door assembly, as required.
20. Remove the screws and the washers previously used on the existing clamps (17) located at STA 15.62 and proceed as follows:
  - a. Bond the radius blocks (16) to the right and left battery compartment webs with adhesive (C-317).
  - b. Install the clamps (17) and the washers (18) with the studs (19). Install the bushings (20), cable assembly (21), and washers (22) with the nuts (23).

-NOTE-

Installation of the cable assembly (21), while the battery door assembly (8) is fully open, will ensure proper orientation of the cable lug once the battery door assembly is fully closed.

21. While the battery door assembly (8) is fully open, install the two cable assemblies (21) to the clips (13) with the washer (24) and the rivet (25).
22. Make an entry in the helicopter logbook and historical service records indicating compliance with **PART I** of this Technical Bulletin. Proceed to **PART II** of this bulletin.

**PART II: Installation of Battery Door Seal 206-031-478-203**

1. Apply adhesive (C-300) on the faying surfaces of the seal (26) and the seal support (27). Install the seal as shown (Figure 1, Detail C, Section D-D).
2. Make an entry in the helicopter logbook and historical service records indicating compliance with **PART II** of this Technical Bulletin.

**PART I**

206A/B serial numbers 004 through 3566.

[206B serial number 3567 and subsequent will have the intent of **PART I** of this bulletin accomplished prior to delivery.]

[TH-67 serial number 5101 and subsequent will have the intent of **PART I** of this bulletin accomplished prior to delivery.]

**PART II**

206A/B serial numbers 004 through 4570.

TH-67 serial numbers 5101 through 5291.

[206B serial number 4571 and subsequent will have the intent of **PART II** of this bulletin accomplished prior to delivery.]

[TH-67 serial number 5292 and subsequent will have the intent of **PART II** of this bulletin accomplished prior to delivery.]

**Table 1 - Helicopters Affected**

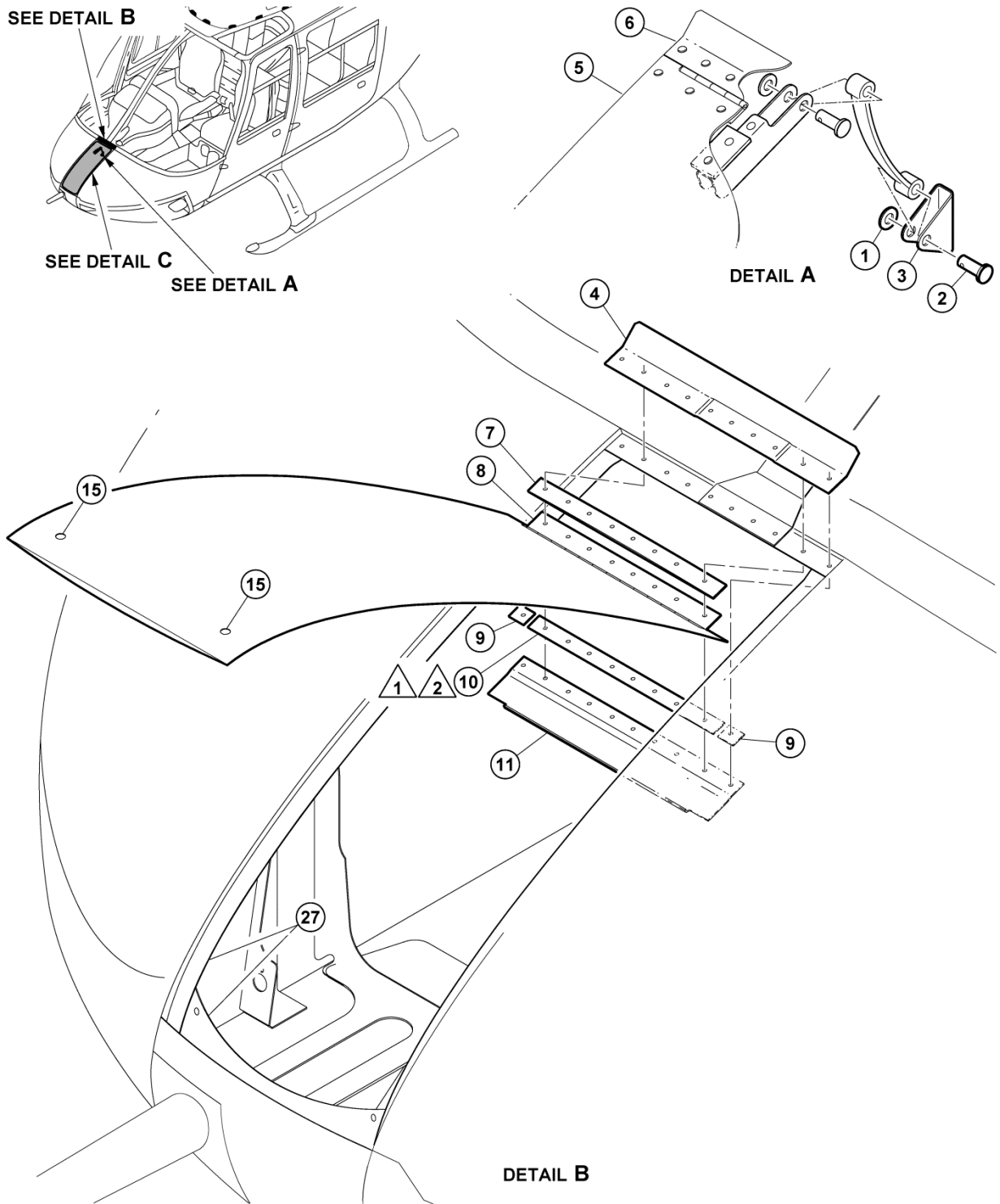

11578\_001a

**Figure 1 - Installation of Battery Door Assembly and Door Seal (Sheet 1 of 3)**

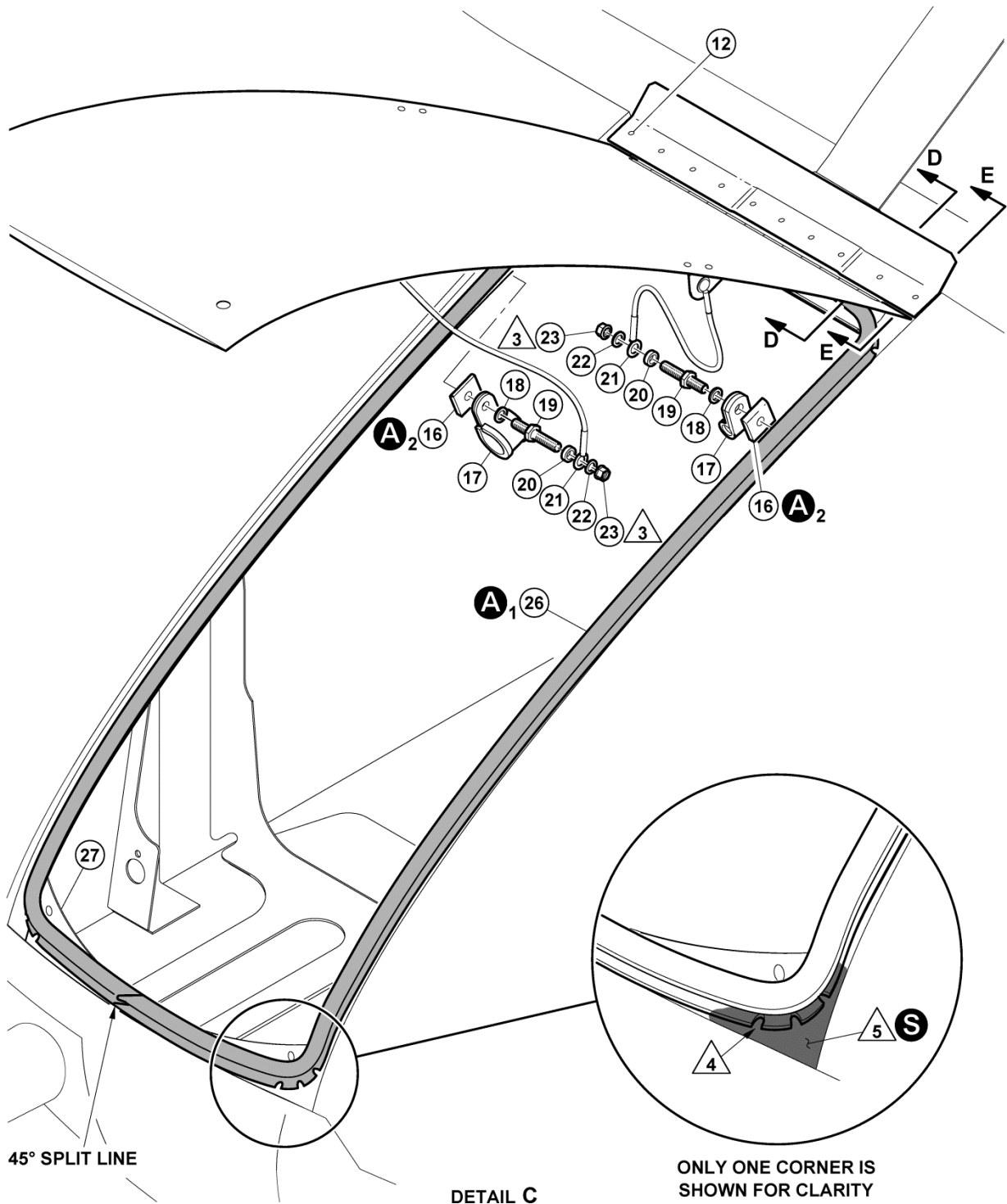

11578\_001b

**Figure 1 - Installation of Battery Door Assembly and Door Seal (Sheet 2 of 3)**

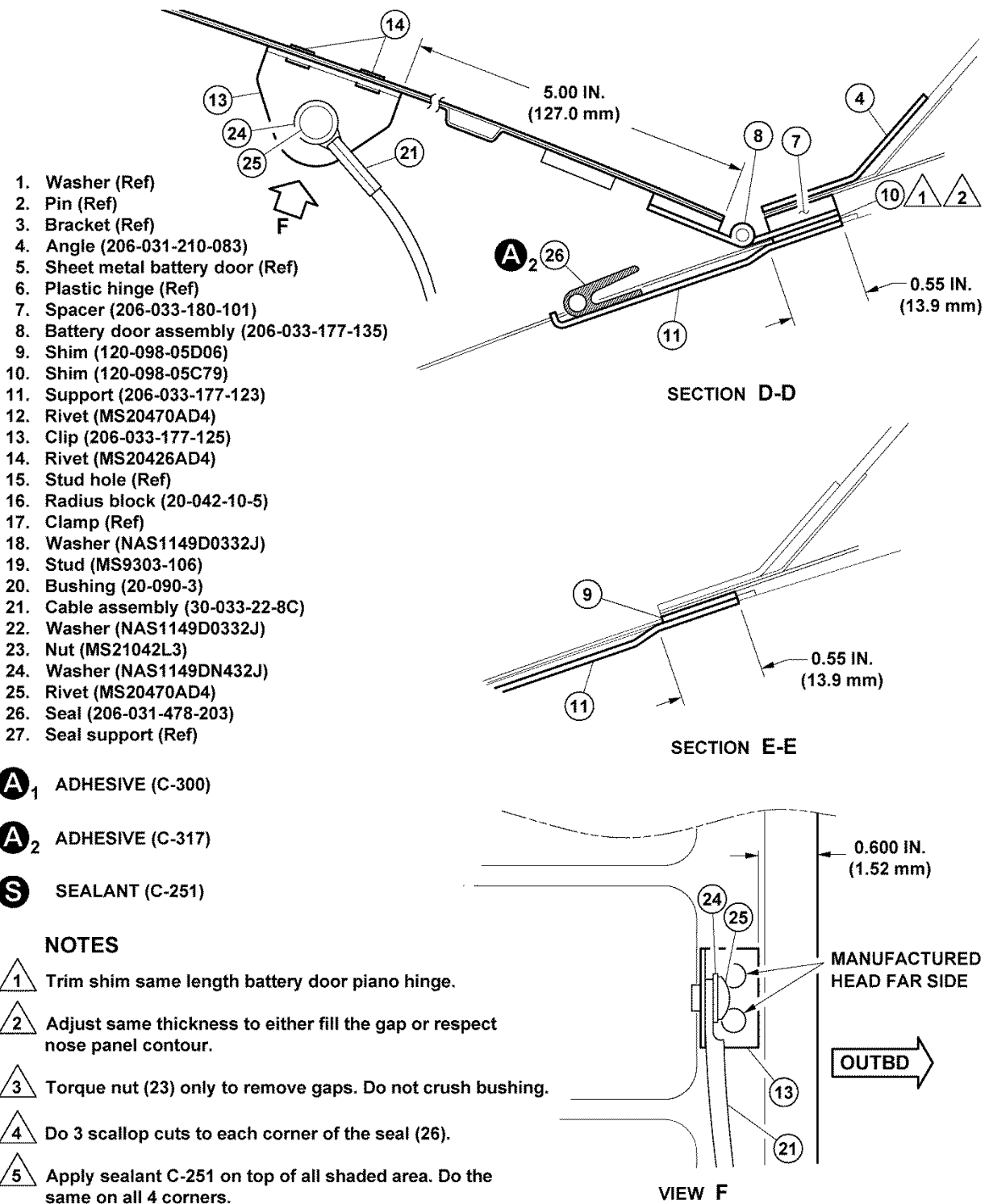

11578\_001c

**Figure 1 - Installation of Battery Door Assembly and Door Seal (Sheet 3 of 3)**