

ALERT SERVICE BULLETIN

UH-1H-17-19

16 March 2017

MODEL AFFECTED: UH-1H

SUBJECT: MAGNETIC BRAKE ASSEMBLY 204-001-376-003
INSPECTION AND REPAIR OF.

HELICOPTERS AFFECTED: ALL UH-1H HELICOPTERS

COMPLIANCE: Within the next 300 flight hours or 12 months
whichever comes first after the release of this bulletin
and every 300 flight hours or 12 months thereafter.

DESCRIPTION:

Bell Helicopter has received reports of magnetic brake assembly P/N 204-001-376-003 (Memcor-Truohm P/N MP498-3) adjustable stop assembly contacting the magnetic brake arm. With time in service, the stop assembly shaft may debond from the housing, back out and cause interference or limit the magnetic brake arm range of motion. This condition, although not desirable, will not affect the proper function of the flight controls.

Part I of this bulletin mandates an inspection of the stop assemblies for condition.

Part II provides a repair procedure if the stop assembly shaft is found debonded.

Applicability of this bulletin to any spare part shall be determined prior to its installation on an affected helicopter.

APPROVAL:

The engineering design aspects of this bulletin is Bell Helicopter Engineering approved.

CONTACT INFO:

For any questions regarding this bulletin, please contact:

Bell Helicopter Product Support Engineering - Medium Helicopters
Tel: 817-280-8377 / mts-medium@bh.com

MANPOWER:

No additional man-hours are required to accomplish Part I of this bulletin when accomplished during the scheduled 300 Hour/12 Month inspection. Approximately 2.5 man-hours may be required to accomplish Part II of this bulletin. This estimate is based on hands-on time and may vary with personnel and facilities available.

WARRANTY:

There is no warranty credit applicable for parts or labor associated with this bulletin.

MATERIAL:

Required Material:

None required.

Consumable Material:

The following material is required to accomplish this bulletin, but may not require ordering, depending on the operator's consumable material stock levels. This material may be obtained through your Bell Helicopter Textron Supply Center.

<u>Part Number</u>	<u>Nomenclature</u>	<u>Qty (Note)</u>	<u>Reference *</u>
2000-09182-01	Adhesive 299-947-100 Ty 2, Cl 2	A/R (1)	C-317
2010-05847-00	Adhesive/sealant MILS22473 GR AA 50cc	A/R (2)	C-320

* C-XXX numbers refer to the consumables list in the BHT-ALL-SPM, Standard Practices Manual

NOTES:

1. The part number 2000-09182-01 is for 50 grams. Negligible quantity of adhesive will be required to accomplish Part II of this bulletin.
2. Required only if the stop assembly screw is removed.

SPECIAL TOOLS:

None required.

WEIGHT AND BALANCE:

Not affected.

ELECTRICAL LOAD DATA:

Not affected.

REFERENCES:

TM 55-1520-210-23 TM Technical Manual
BHT-ALL-SPM

PUBLICATIONS AFFECTED:

TM 55-1520-210-23 TM Technical Manual

ACCOMPLISHMENT INSTRUCTIONS:

Part I. Magnetic brake assembly inspection.

1. Prepare the helicopter for maintenance.
2. Gain access to the cyclic and anti-torque magnetic brake assembly.
3. Perform a detailed visual inspection of the stop assemblies (Figures 1 and 2). Figures 3 and 4 show a stop assembly found debonded.
4. Pull on the stop assembly by hand to verify if the stop shaft is debonded from the housing assembly. If the shaft shows evidence of debonding, inspect the lower side of the arm for possible chafing damage. Repair allowable damage and then accomplish Part II. The maximum allowable mechanical damage is 0.030 inch. Repair allowable chafing damage as follows:
 - a. Using 220 grit of finer abrasive cloth or aluminum oxide paper, polish out mechanical damage found within the allowable 0.030 inch
 - b. Apply aluminum alloy chemical film treatment to the repaired area (BHT-ALL-SPM).
 - c. If the mechanical damage exceeds the limitation contact Product Support Engineering.

5. If the shaft does not show any evidence of debonding, make an entry in the helicopter records to indicate compliance with this Alert Service Bulletin.

Part II. Stop assembly shaft bonding.

1. Disconnect the helicopter battery.
2. Remove the magnetic brake assembly.
3. Mark the stop assembly and the housing for installation at the same location.
4. Remove the stop assembly from the housing. (Figure 4)
5. Thoroughly clean adhesive residue from the shaft and the housing bore. If the splined stop requires removal from the shaft, index mark the stop, the shaft and the housing to ensure installation at the same location.
6. Apply adhesive (C-317) to the mating surfaces of the housing and the shaft.
7. Install the stop assembly in the housing bore and remove excess of adhesive.
8. The shaft should protrude from the housing surface between 0.180 inch and 0.200 inch. (Figure 2).
9. Allow sufficient time for the adhesive (C-317) to cure (24 hours at 70 to 95 °F)
10. Verify/adjust stop limits to achieve the arm assembly travel. If the screw is removed from the shaft, reinstall with adhesive (C-320) and torque to 5-10in-lb. (Figures 5 and 6)
11. Reinstall magnetic brake assembly in accordance with maintenance manual.
12. Make an entry in the helicopter records to indicate compliance with this Alert Service Bulletin.

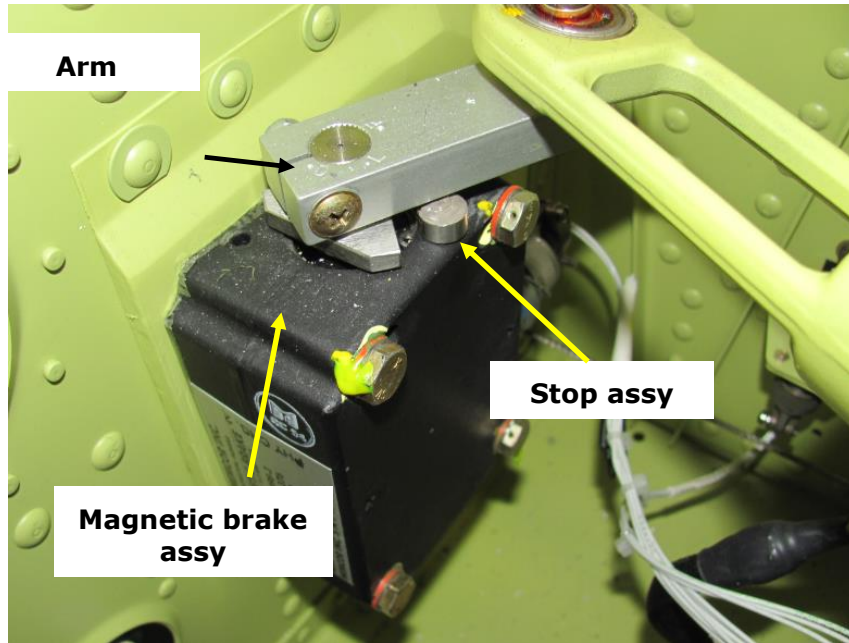

Figure 1. Magnetic brake assembly.

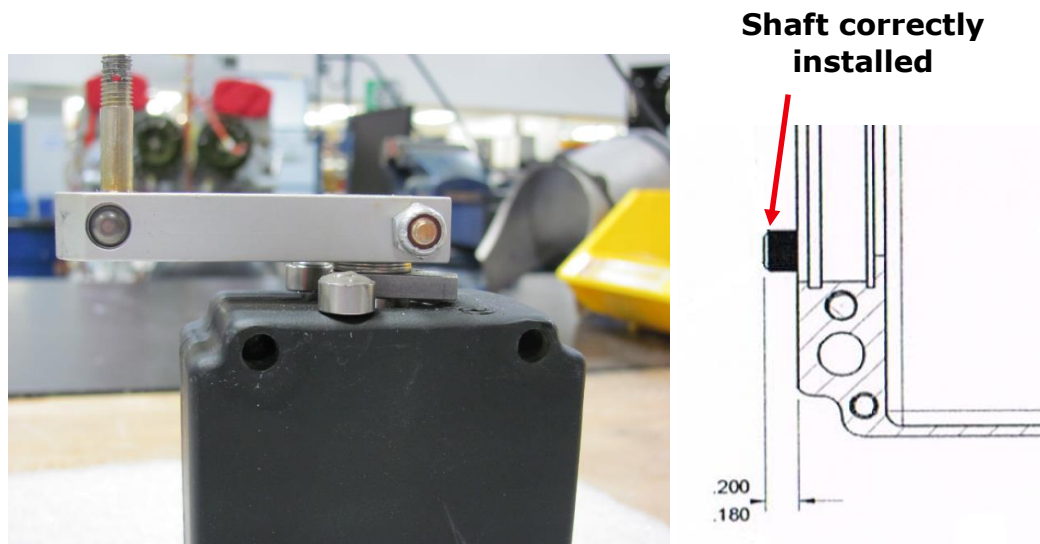

Figure 2. Magnetic brake assembly with stops correctly installed.
 (Magnetic brake 204-001-376-003 shown as an example Figures 1 to 4)

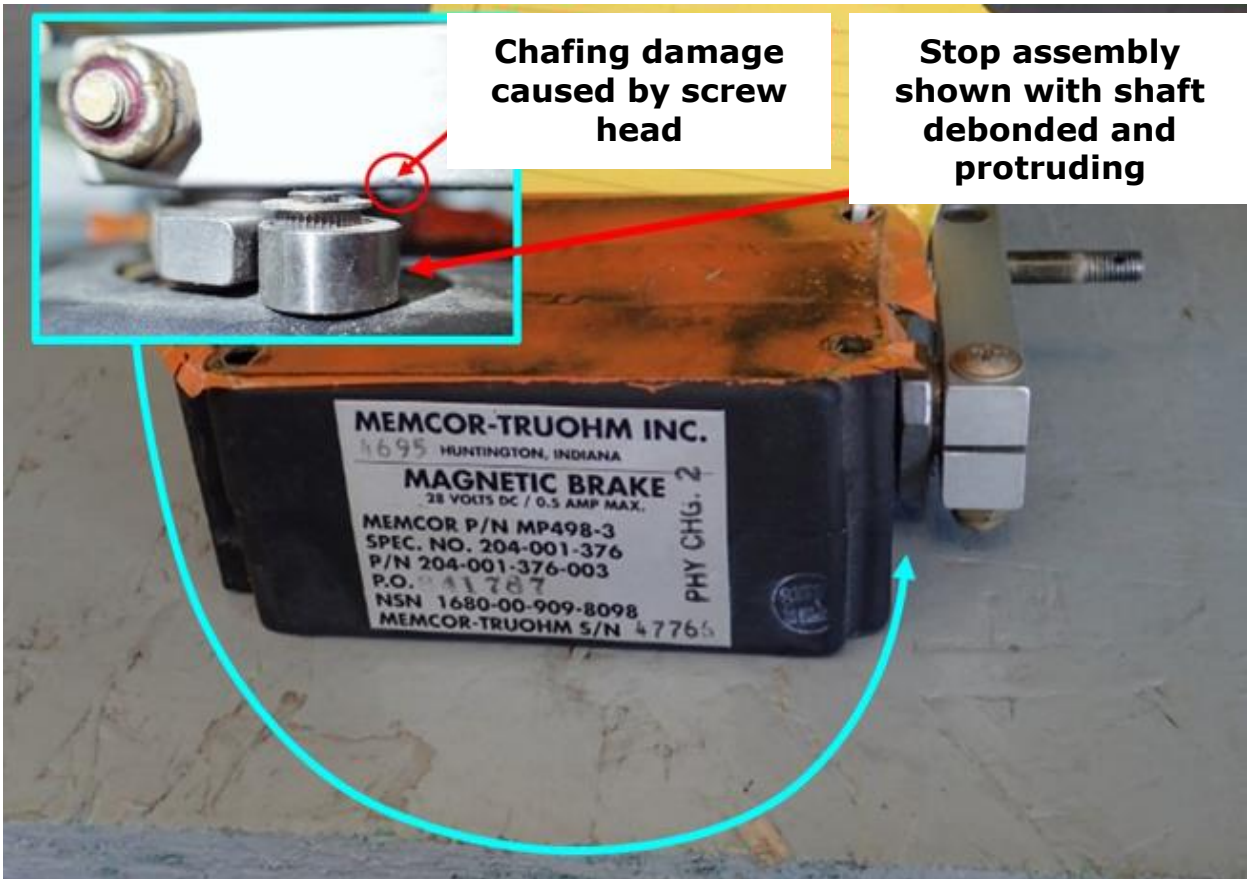

Figure 3. Stop assembly with debonded shaft.

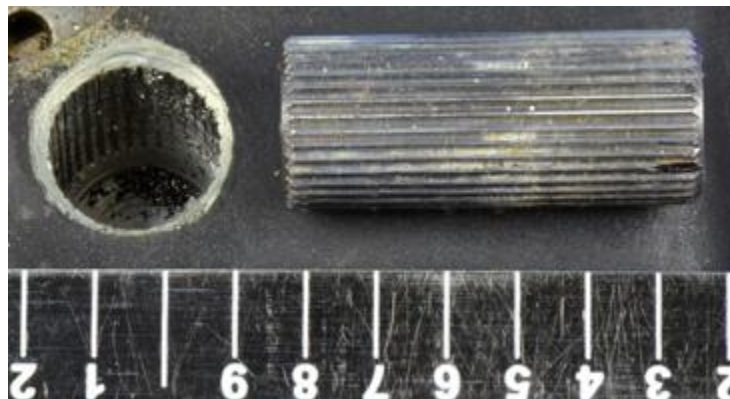

Figure 4. Shaft removed from housing.

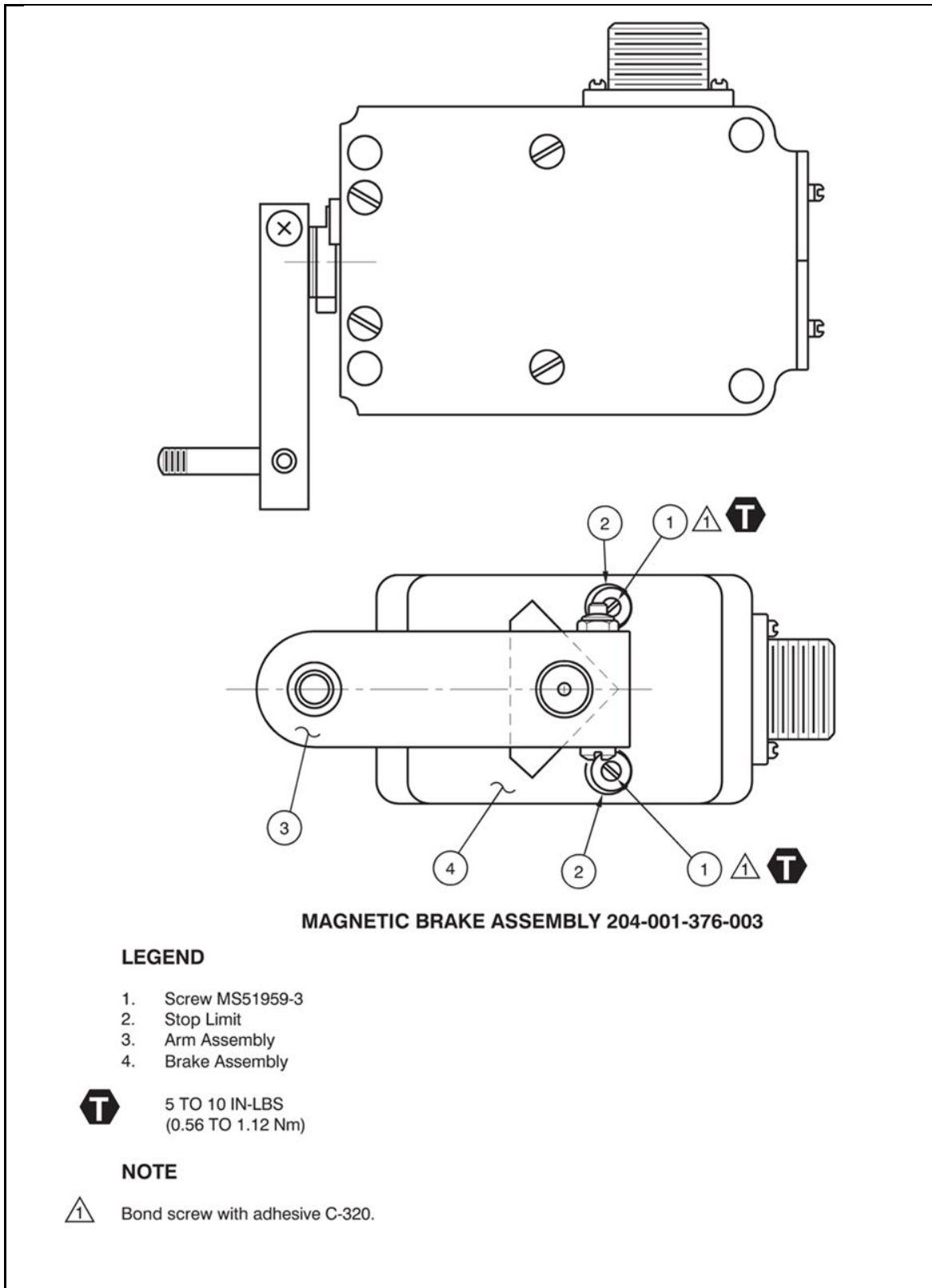
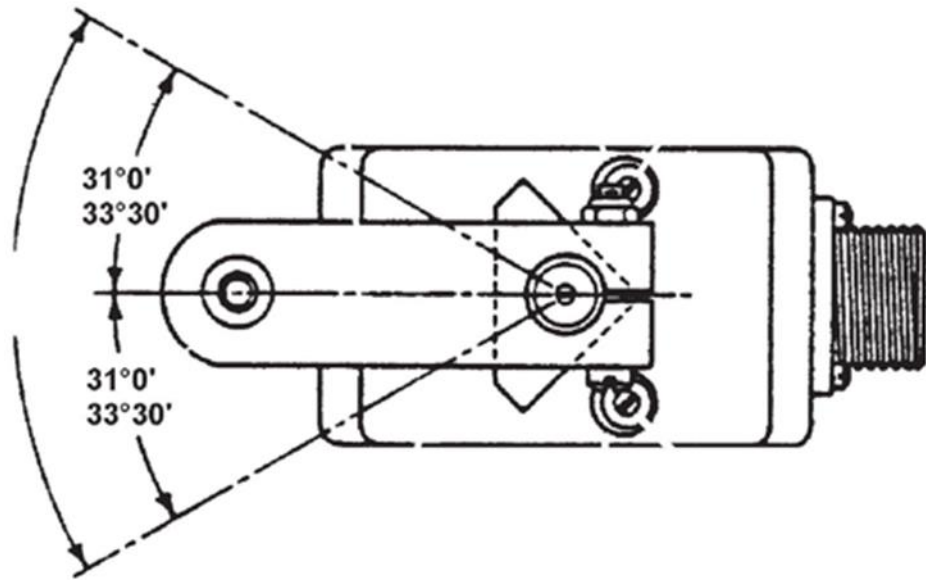

Figure 5. Adjustable Stop Assembly Installation



-NOTE-

Regardless of arm letter indexing, total travel of the arm in relation to the stops is the same. Arm position shown would be for a cyclic controls installation.

Figure 6. Stop Assembly Travel