



A Textron Company

ALERT SERVICE BULLETIN

429-19-47

28 August 2019

Revision A, 2 November 2020

Revision B, 27 January 2021

MODEL AFFECTED: 429

SUBJECT: TAIL ROTOR GEARBOX SUPPORT RETAINING RIVETS, INSPECTION OF.

HELICOPTERS AFFECTED: **Part I - Serial numbers 57002 through 57210, 57212 and subsequent.**

[Serial number 57001 and 57211, will have the intent of this bulletin accomplished prior to delivery.]

Part II – Serial numbers 57001 and subsequent.

COMPLIANCE: **Part I** - Upon reaching 300 hours Total Time Since New (TTSN) or 300 or more flight hours since replacement of the tail rotor gearbox support assembly, the inspection shall be accomplished within 100 hours or 6 months, whichever comes first after the release of this bulletin. For helicopters that have exceeded 300 hours TTSN, the inspection shall be accomplished within 100 hours or 6 months, whichever comes first after the release of this bulletin.

Part II - Every 400 hours or 12 months, whichever comes first. Helicopters having flown in excess of 400 hours or that have exceeded 12 months since complying with the initial release of this bulletin shall perform **Part II** within 100 hours or 6 months, whichever comes first.

DESCRIPTION:

Bell has received reports of failed rivets at the joint between the tailboom skin and the tail rotor gearbox supports 429-034-701-101 or 429-035-705-101. To address this, Bell is issuing this bulletin to mandate a recurring inspection of the rivets located in that joint. Applicability of this bulletin to any spare part shall be determined prior to its installation on an affected helicopter.

Revision A of this bulletin introduces a recurring inspection every 400 hours or 12 months, whichever comes first, which is to be performed after the **Part I** initial inspection. Operators that have already complied with the original release of this bulletin do not have to perform **Part I** of this revision.

Revision B of this bulletin introduces changes to the compliance section for **Part I**, the description section, the materials section and to the accomplishment instructions.

APPROVAL:

The engineering design aspects of this bulletin are Transport Canada Civil Aviation (TCCA) approved.

CONTACT INFO:

For any questions regarding this bulletin, please contact:

Bell Product Support Engineering
Tel: 1-450-437-2862 / 1-800-363-8023 / productsupport@bellflight.com

MANPOWER:

Approximately 1.5 man-hours are required to complete **Part I** of this bulletin. Approximately 1.5 man-hours are required to complete **Part II** of this bulletin. This estimate is based on hands-on time and may vary with personnel and facilities available.

WARRANTY:

There is no warranty credit applicable for parts or labor associated with this bulletin.

MATERIAL:

Consumable Material:

The following material is required to accomplish this bulletin, but may not require ordering, depending on the operator's consumable material stock levels. This material may be obtained through your Bell Supply Center.

<u>Part Number</u>	<u>Nomenclature</u>	<u>Qty (Note)</u>	<u>Reference *</u>
2010-05970-00	Sealant	1 Pt	C-559

* C-XXX numbers refer to the consumables list in the BHT-ALL-SPM, Standard Practices Manual

SPECIAL TOOLS:

None required.

WEIGHT AND BALANCE:

Not affected.

ELECTRICAL LOAD DATA:

Not affected.

REFERENCES:

BHT-429-IPB Illustrated Parts Breakdown
BHT-429-MM Maintenance Manual
BHT-ALL-SRM Structural Repair Manual

PUBLICATIONS AFFECTED:

BHT-429-MM Maintenance Manual

ACCOMPLISHMENT INSTRUCTIONS:

Part I – Initial Inspection

1. Prepare the helicopter for maintenance.
2. Remove the panel 500F (DMC-429-A-53-00-00-30A-520A-A).
3. Remove the forward and aft tail rotor driveshaft covers (500A and 500B) (DMC-429-A-53-00-00-53A-520A-A).
4. Remove the tail rotor gearbox covers (500G) (DMC-429-A-53-00-00-54A-520A-A).

-NOTE-

Failed rivets are those whose head has separated from their tail. Improper length rivets are rivets for which the tails are not resting against the tailboom skin and that do not come out when pulled by hand or with the aid of pliers.

5. Do a general visual inspection of the external surface of the tail rotor gearbox support for any failed rivet heads.

-NOTE-

It is permissible to use a borescope to facilitate the inspection of the rivet tails inside the tailboom.

6. With a bright light and mirror, visually inspect all the rivet tails inside of the tailboom for the following conditions:
 - a. Rivets tails that are not resting against the tailboom skin.
 - b. Missing tails, or tails resting at the bottom of the tailboom.

CAUTION

Pliers can also be used to facilitate the tactile check. Make sure that the serrations on the plier mandibles are protected with tape to avoid damaging the tail of the rivet.

7. Do a tactile check of all the rivets identified in Figure 1 by pulling on each rivet tail.
8. Using Figure 1 to identify the position of the rivets, note the position of any discrepant rivet found during steps 5, 6, and 7 in Table 1.

-NOTE-

If gaps have already been measured and repaired where rivets have previously failed during compliance with the initial release of this bulletin, steps 9.b. through 9.f. are not required, and failed rivets can be replaced per BHT-ALL-SRM, Chapter 3.

9. If no discrepant rivets were found, proceed to step 12. If discrepant rivets were found during steps 5, 6 and 7, do the following:

- a. Determine if the discrepant rivets are failed or if they are of improper length.
 - (1) If the rivets are of improper length, replace the rivets per BHT-ALL-SRM, Chapter 3 and proceed to step 10.
 - (2) If the rivets are failed, proceed to step 9.b.
- b. Remove the edge sealant from the forward edge of the tail rotor gearbox support.
- c. Using a feeler gauge, measure any gaps present between the tail rotor gearbox support and the tailboom skin.
- d. Plot the location of the gaps by using Figure 1 and Table 1.
- e. If no gaps or if gaps measuring 0.005" (0.127 mm) or less are found, replace the discrepant rivets per BHT-ALL-SRM, Chapter 3 and proceed to step 10. If gaps in excess of 0.005" (0.127 mm) are present, proceed to the next step.
- f. Submit a structural repair request in accordance with General Information Letter GEN-18-141. Make sure to submit the information recorded in step 9.d.
- g. Repair the gaps and replace rivets in accordance with the approved Bell structural repair scheme that will be provided after having submitted the repair request in step 9.f and proceed to step 10

-NOTE-

Table 1 must be completed and sent to Bell only if discrepant rivets are found.

10. Complete Table 1 and submit to Bell Product Support Engineering at productsupport@bellflight.com. Make sure that the following information is included in the subject line:
 - a. Helicopter serial number
 - b. The ASB number: ASB-429-19-47
11. If sealant was removed during step 9.b and no excessive gaps were found in step 9.c, re-apply sealant (C-559) as required.
12. Install the tail rotor gearbox fairing (500G) (DMC-429-A-53-00-00-52A-720A-A).
13. Install the forward and aft tail rotor driveshaft covers (500A and 500B) (DMC-429-A-53-00-00-51A-720A-A).
14. Install panel 500F (DMC-429-A-53-00-00-28A-720A-A).

15. Make an entry in the helicopter logbook and historical service records indicating compliance with **Part I** of this Alert Service Bulletin.

Part II – Recurring inspection

1. Carry out steps 1 through 14 from **Part I** of this bulletin every 400 hours or 12 months, whichever comes first.
2. Make an entry in the helicopter logbook and historical service records indicating compliance with **Part II** of this Alert Service Bulletin.

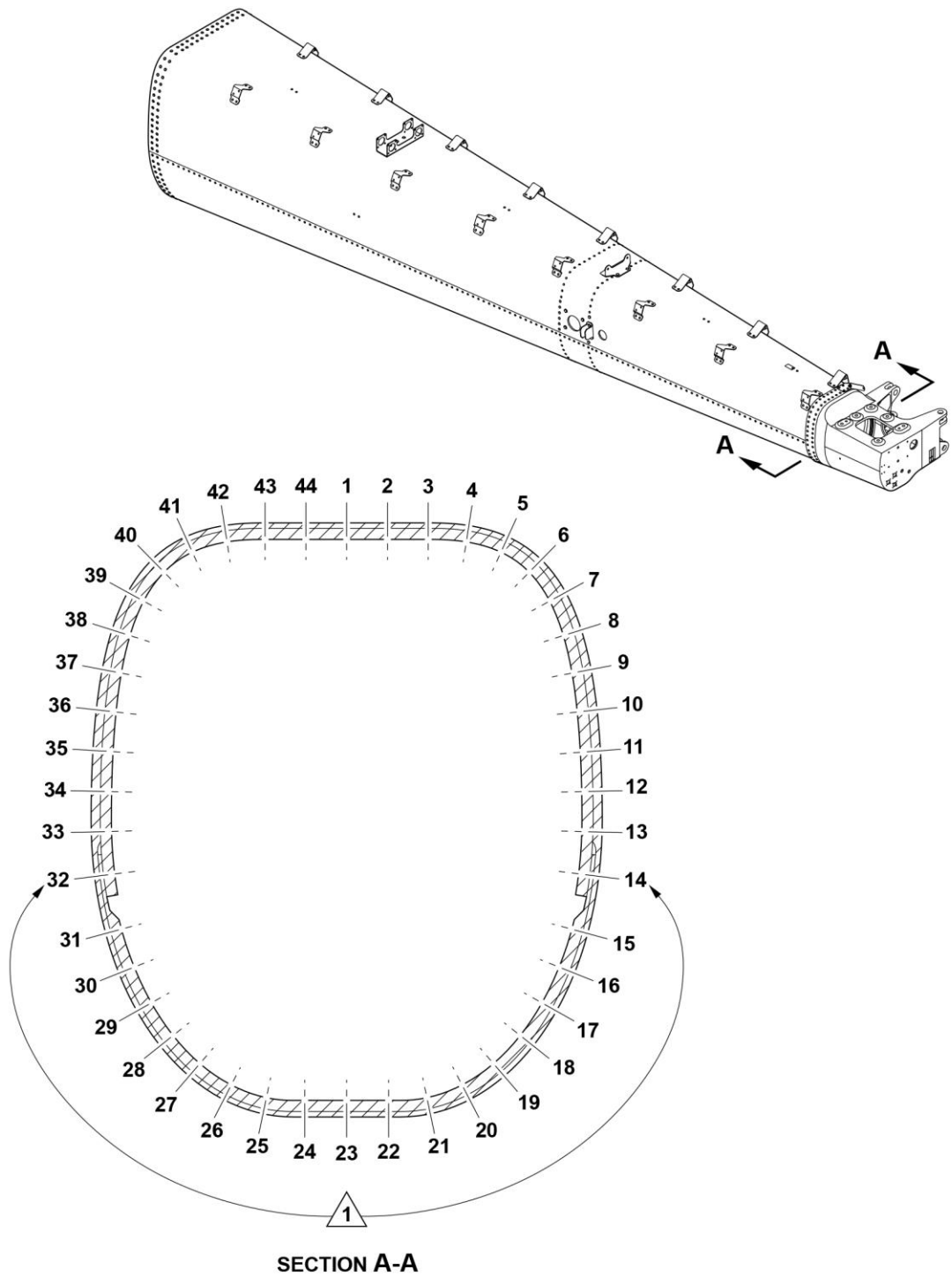

NOTE



Perform tactile check on indicated rivet tails.

Figure 1 – Rivet Identification

19879_001

Table 1 – Inspection Results

Helicopter Information	
Serial Number	
Total Time Since New	
Owner/Operator	
Registration	
Geographical Location	

Answer YES for each discrepant rivet or NO for rivets that are found in good condition							
RIVET ROW #	FWD RIVET ROW	AFT RIVET ROW	Gap (if applicable)	RIVET ROW #	FWD RIVET ROW	AFT RIVET ROW	Gap (if applicable)
1				23			
2				24			
3				25			
4				26			
5				27			
6				28			
7				29			
8				30			
9				31			
10				32			
11				33			
12				34			
13				35			
14				36			
15				37			
16				38			
17				39			
18				40			
19				41			
20				42			
21				43			
22				44			