



A Textron Company

ALERT SERVICE BULLETIN

206L-19-181

27 August 2019

Revision A, 29 August 2019

MODEL AFFECTED: 206L, 206L-1, 206L-3 and 206L-4

SUBJECT: TAIL ROTOR DRIVESHAFT DISC PACK
COUPLING NUTS, REPLACEMENT OF

HELICOPTERS AFFECTED: Serial numbers 45001 through 45153, 46601
through 46617, 45154 through 45790, 51001
through 51612 and, 52001 through 52496.

COMPLIANCE: Within the next 300 flight hours but no later than
15 September 2020.

DESCRIPTION:

Bell has received reports of cracked or missing MS21042 series nuts. Conditions leading to cracked or missing MS21042 nuts may be attributed to improper torque applied, low tare torque, or hydrogen embrittlement. A review of several Service Difficulty Reports has concluded that the events were related to the loss of hardware from tail rotor disc pack (Thomas) couplings.

The Model 206 series helicopters use four (4) MS21042 nuts at each tail rotor driveshaft disc pack coupling attachment. Depending on the model and configuration, as many as twenty-eight (28) or thirty-six (36) MS21042L4 nuts are used in the tail rotor driveshaft installations.

This Alert Service Bulletin (ASB) mandates the replacement of the MS21042L4 nuts with the 12-point NAS9926-4L corrosion resistant steel nuts.

As additional information, General Information Letter GEN-18-138 was recently issued to advise owners and operators of the recent supersession of some of the MS21042 and NAS1291 series nuts by the NAS9926 series nuts.

Applicability of this bulletin to any spare part shall be determined prior to its installation on an affected helicopter.

Revision A of this bulletin corrects the ASB number referenced in the ACCOMPLISHMENT INSTRUCTIONS at step 4.

APPROVAL:

The engineering design aspects of this bulletin are Transport Canada Civil Aviation (TCCA) approved.

CONTACT INFO:

For any questions regarding this bulletin, please contact:

Bell Product Support Engineering
LIGHT Tel: 450-437-2862 / 1-800-363-8023 / productsupport@bellflight.com

MANPOWER:

Approximately 4.0 man-hours are required to complete this bulletin. This estimate is based on hands-on time and may vary with personnel and facilities available.

WARRANTY:

There is no warranty credit applicable for parts or labor associated with this bulletin.

MATERIAL:

Required Material:

The following material is required for the accomplishment of this bulletin and may be obtained through your Bell Supply Center.

<u>Part Number</u>	<u>Nomenclature</u>	<u>Qty (Note)</u>
CA-206L-19-181-1	KIT, 28-NUT, 206L	(1)(3)
CA-206L-19-181-2	KIT, 36-NUT, 206L	(2)(3)

NOTES:

1. Quantity twenty-eight (28) NAS9926-4L nuts required for 206L-1 or 206L-3 helicopters having Service Instruction BHT-206-SI-2052 (Increased Gross Weight Kit) incorporated and for the 206L-4.
2. Quantity thirty-six (36) NAS9926-4L nuts required for 206L, 206L-1 and 206L-3 that do not have BHT-206-SI-2052 (Increased Gross Weight Kit) incorporated.
3. The kits are policy-priced and only made available on a one-time basis per ship serial number; thereafter, the nuts will only be available at the current price.

Consumable Material:

The following material is required to accomplish this bulletin, but may not require ordering, depending on the operator's consumable material stock levels. This material may be obtained through your Bell Supply Center or procured locally.

<u>Part Number</u>	<u>Nomenclature</u>	<u>Qty (Note)</u>	<u>Reference *</u>
2230-10536-00	Torque Seal Lacquer	A/R (1, 2)	C-049

* C-XXX numbers refer to the consumables list in the BHT-ALL-SPM, Standard Practices Manual

NOTES:

1. Torque Seal Lacquer color at customer's option. (Yellow color part number shown)
2. May be procured locally.

SPECIAL TOOLS:

None required.

WEIGHT AND BALANCE:

Negligible.

ELECTRICAL LOAD DATA:

Not affected.

REFERENCES:

BHT-206L-MM Maintenance Manual
BHT-206L1-MM Maintenance Manual
BHT-206L3-MM Maintenance Manual
BHT-206L4-MM Maintenance Manual
BHT-ALL-SPM Standard Practices Manual

PUBLICATIONS AFFECTED:

None affected.

ACCOMPLISHMENT INSTRUCTIONS:

1. Prepare the helicopter for maintenance.

2. Remove and replace the MS21042L4 nuts at each tail rotor driveshaft disc pack coupling with the 12-point NAS9926-4L nuts (refer to applicable 206L Maintenance Manual, Chapter 65). There are four (4) nuts at each disc pack coupling attachment (Figure 1).
3. After torquing nuts, apply a torque stripe (witness mark) to each nut using the torque seal lacquer (C-049), or equivalent (Figure 2). Application of the torque seal lacquer (C-049) is used to mark the nuts that have been torqued to visually identify movement of the nuts. Torque seal is brittle and will crack if the fastener moves.
4. If any MS21042L4 nuts are found loose or damaged, report at which location and provide the information to Product Support Engineering at productsupport@bellflight.com

Ensure the following information is in the subject line of the email:

- a. Service Directive number: ASB 206L-19-181
 - b. Model and serial number of the affected helicopter.
 - c. Operator name
5. Make an entry in the helicopter logbook and historical service records indicating findings and compliance with this Alert Service Bulletin.

-NOTE-

Perform Special Inspection 5-47, 5-48, 5-49, 5-50, as applicable, (Disc Pack Coupling Torque Check) 10 to 25 hours after installation (refer to applicable 206L Maintenance Manual, Chapter 5). Re-apply torque seal lacquer (C-049), or equivalent, as required (Figure 2).

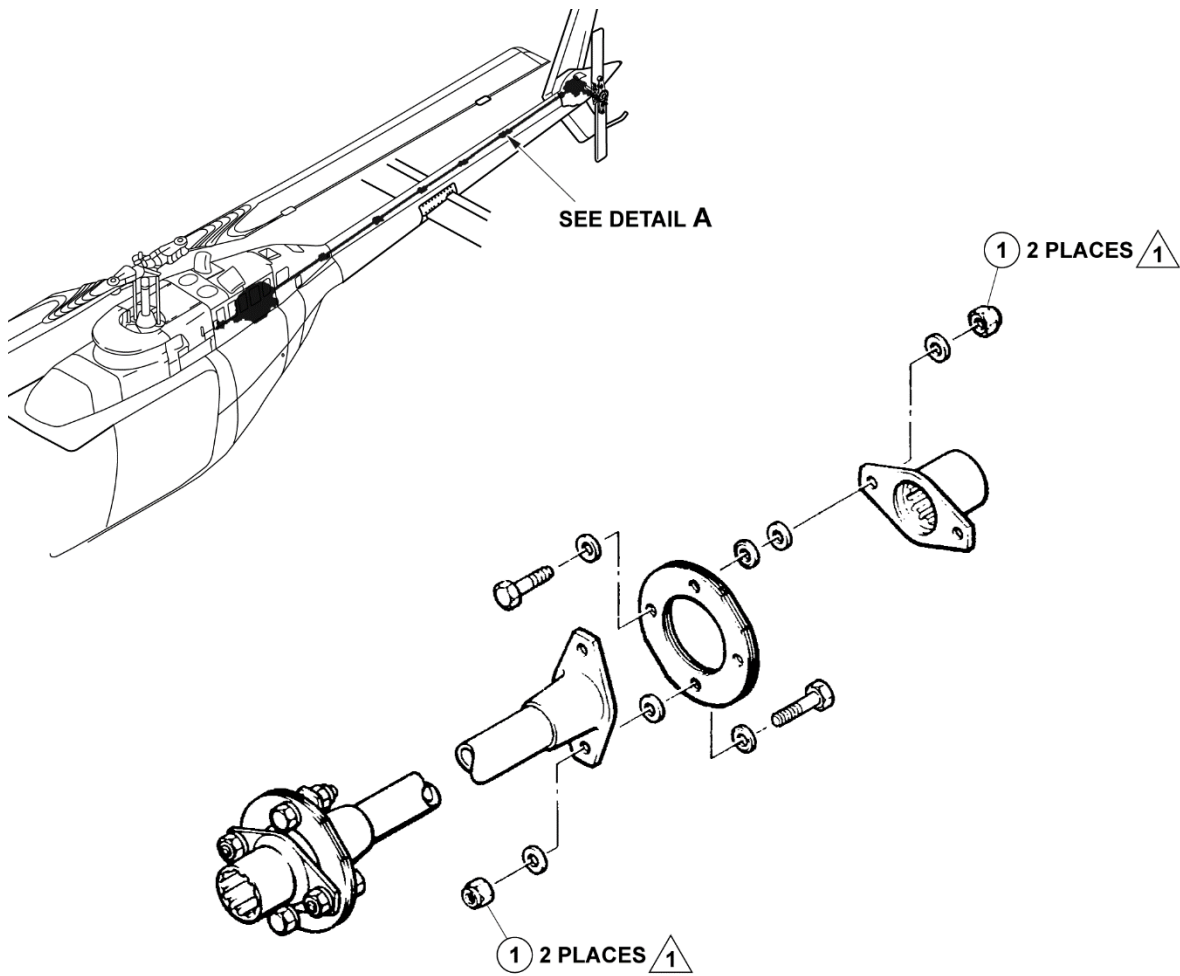

**DETAIL A
(9 PLACES)**

- 1. Nut (NAS9926-4L) 4 Reqd.

NOTES

- 1 Thirty-six (36) nuts required for the 206L (S/N 45004 through 45153 and 46601 through 46617), 206L-1 (S/N 45154 through 45790), and 206L-3 (S/N through 51612).
- 2 Twenty-eight (28) nuts required for the 206L-4 (S/N 52001 through 52492) and for 206L-1 or 206L-3 helicopters having Service Instruction BHT-206-SI-2052 (Increased Gross Weight Kit) incorporated.

18830_001b

Figure 1 - Typical Tail Rotor Driveshaft Disc Pack Coupling Attachments



Figure 2 - Application of Torque Seal Lacquer (witness mark)
(Shown as a yellow stripe from the nut to the adapter flange)