

TECHNICAL BULLETIN
Bell Helicopter

A Textron Company

No. 205-09-125

Date April 28, 2009

Page 1 of 5

DATE
REV

MODEL AFFECTED: 205

SUBJECT: TAIL ROTOR GEARBOX EXCLUDER HOUSING
LEAK: PREVENTION OF

HELICOPTERS AFFECTED: All Model 205A and 205A-1 helicopters.

COMPLIANCE: At customer's option

DESCRIPTION:

Recently there have been several reported cases of oil leakage from the tail rotor gearbox between the pitch change housing and the excluder housing. These occurrences have been noticed on both new production gearboxes and those with many hours in service. Sealing the metal to metal contact area between the excluder housing and the gearbox pitch change housing will eliminate the oil leakage.

This bulletin provides the procedure to prevent this oil leak at the tail rotor gearbox pitch change housing.

APPROVAL:

The engineering design aspects of this bulletin are FAA/DER approved.

MANPOWER:

Approximately 1.0 man-hours are required to complete this bulletin. Man-hours are based on hands-on time, and may vary with personnel and facilities available.

WARRANTY:

There is no warranty credit applicable for parts or labor associated with this bulletin.

MATERIAL:

Consumable Material:

The following material is required to accomplish this bulletin; however this material is considered consumable (bench stock) material and may not require ordering depending on the operator's consumable material stock levels. This material may be obtained through your Bell Helicopter Textron Supply Center.

<u>Part Number</u>	<u>Nomenclature</u>	<u>Quantity</u>	<u>Reference</u>
299-947-074, Type 3	Sealant	A/R	C-328
ASTM D329	Acetone	A/R	C-316

SPECIAL TOOLS:

None required

WEIGHT AND BALANCE:

Not affected

ELECTRICAL LOAD DATA:

Not affected

REFERENCES:

BHT-205-IPB Illustrated Parts Breakdown
BHT-205-MM Maintenance Manual

PUBLICATIONS AFFECTED:

BHT-205-MM Maintenance Manual

ACCOMPLISHMENT INSTRUCTIONS:

1. Make helicopter ready for maintenance.
2. Refer to Figures 1 and 2. Remove retaining ring (1) and extract excluder housing (2) by applying pressure on the tail rotor controls from full right pedal to full left. (IF excluder and packing need to be replaced refer to BHT-205-MM for disassembly instructions).
3. Using a clean cloth dampened with acetone (C-316) clean inside diameter of pitch change housing (3) where excluder housing (2) will be installed.
4. Using a clean cloth clean outside diameter of excluder housing (2) with acetone (C-316) and coat with sealant (C-328).
5. Install excluder housing (2) in pitch change housing (3).
6. Using a clean cloth dampened with acetone (C-316) remove excessive sealant and reinstall retaining ring (1).
7. Make an entry in helicopter historical records indicating compliance with this technical bulletin.

Refer to
Figure 2

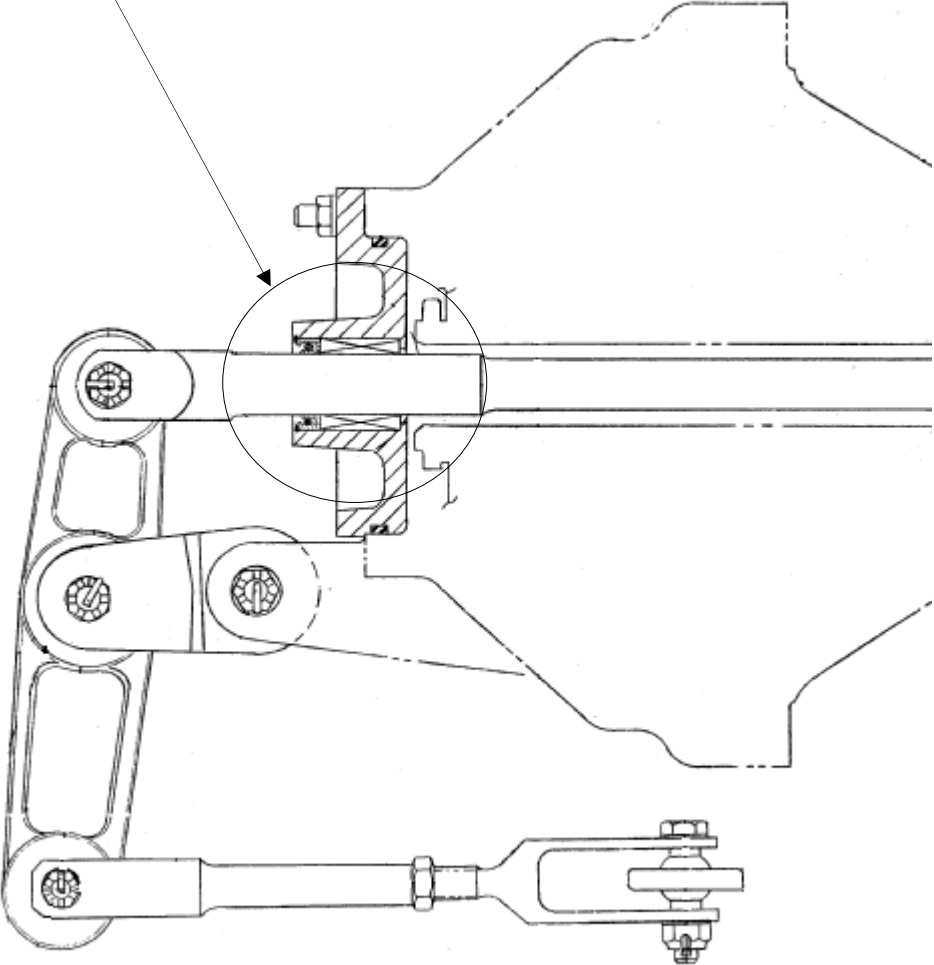

Figure 1

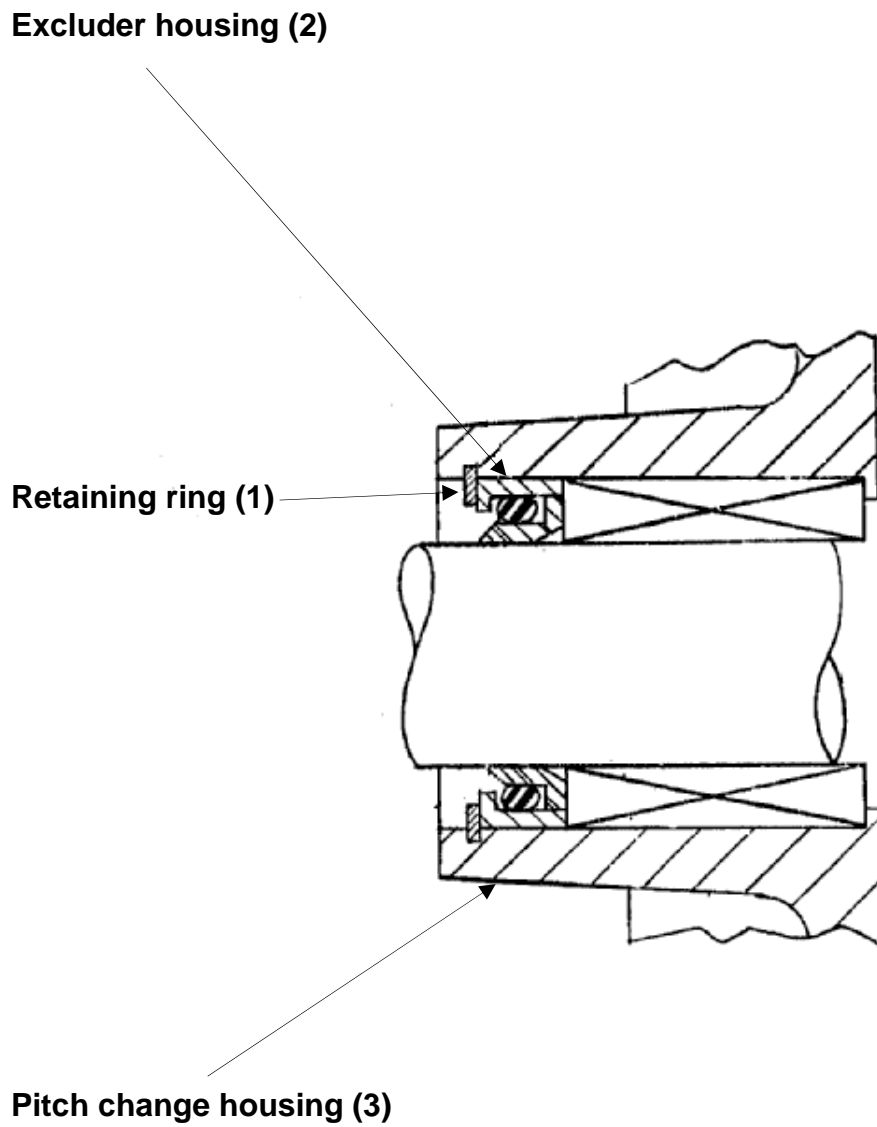

Figure 2