



A Textron Company

ALERT SERVICE BULLETIN

412-24-200

PSL # 2212

4 December 2024

MODEL AFFECTED: 412EP

SUBJECT: ENGINE N1 CONTROL CABLE INSTALLATION, IMPROVEMENT OF.

HELICOPTERS AFFECTED: Serial numbers 39101 through 39121, 39123 through 39126, 39128 and 39132.

[Serial number 39122, 39127, 39129 through 39131, and 39133 through 39999 will have the intent of this bulletin accomplished prior to delivery.]

COMPLIANCE: Within the next 150 flight hours/60 days, whichever occurs first, after the release date of this bulletin.

DESCRIPTION:

Bell has discovered that the current installation of the engine N1 control cables 7-46300-1 and 7-46300-2 require additional support at multiple locations along the routing. This bulletin mandates the installation of additional brackets to provide adequate support and revises the clamping arrangement of the N1 control cable assemblies to improve the installation and avoid interference with the cargo suspension assembly when installed.

APPROVAL:

The engineering design aspects of this bulletin are FAA approved.

CONTACT INFO:

For any questions regarding this bulletin, please contact:

Bell Product Support Engineering
Tel: 1-450-437-2862 / 1-800-363-8023 / productsupport@bellflight.com

MANPOWER:

Approximately 6.0 man-hours are required to complete this bulletin. This estimate is based on hands-on time and may vary with personnel and facilities available.

WARRANTY:

Owners / Operators of Bell Helicopters who comply with the instructions in this bulletin will be eligible to receive replacement parts and Labor as applicable, listed in the bulletin. The www.mybell.com portal allocates specific warranty entitlement for an aircraft by serial number. The Product Service Letter (PSL) number which will be listed below the bulletin number on the introduction page. This is going to be a required field when submitting a claim on the Bulletins Tab for replacement parts, labor, and/or freight. If you receive an ASB or TB that does not have a PSL number, then there is no warranty entitlement for that bulletin.

Labor entitlement: \$660.00 USD

To receive parts, labor, under warranty:

- Comply with the instructions contained in this Bulletin no later than the applicable date in the “compliance section”.
- If there is a PSL number identified in the bulletin you will be required to enter this PSL number which will validate warranty entitlement for the selected aircraft. Please ensure that you use the Bulletin tab on the warranty section on www.mybell.com portal to file your claim.

You can find out to how to submit a warranty claim on the link below.
www.mybell-user-guidebooks

MATERIAL:

Required Material:

The parts listed below are part of the convenience kit CA-412-24-200. The kit **CA-412-24-200** is required for the accomplishment of this bulletin and can be obtained through your Bell Supply Center.

<u>Part Number</u>	<u>Nomenclature</u>	<u>Qty (Note)</u>
412-060-715-113	Bracket Assy	1
20-032-1D	Bracket	1
20-032-2D	Bracket	1
20-032-34D	Bracket	1
AS21919WDG05Y	Clamp	1
MS27039-1-08	Screw	2
MS27039-1-14	Screw	1
NAS1149D0332J	Washer	6
NAS1801-3-9	Screw	1
NAS9301B-4-02	Rivet	5
NAS1149D0432J	Washer	1
NAS43DD3-22N	Spacer	1
NAS9926-3L	Nut	2

Consumable Material:

The following material is required to accomplish this bulletin, but may not require ordering, depending on the operator's consumable material stock levels. This material may be obtained through your Bell Supply Center.

<u>Part Number</u>	<u>Nomenclature</u>	<u>Qty (Note)</u>	<u>Reference *</u>
2100-000700-00	SEALANT-TY II-CL1 GR B-2 MIL-PRF-81733 TYII	3.5 OZ (1)	C-251

* C-XXX numbers refer to the consumables list in the BHT-ALL-SPM, Standard Practices Manual

NOTE 1: Quantity indicated is the format that the product is delivered in. Actual quantity required to accomplish the instructions in this bulletin may be less than what has been delivered

SPECIAL TOOLS:

None required.

WEIGHT AND BALANCE:

Not affected.

ELECTRICAL LOAD DATA:

Not affected.

REFERENCES:

BHT-412EPX-IPBS Illustrated Parts Breakdown Supplement
BHT-412EPX-MMS Maintenance Manual Supplement
412-704-109-101 Retrofit Kit Drawing (Bell internal reference only)

PUBLICATIONS AFFECTED:

BHT-412EPX-IPBS Illustrated Parts Breakdown Supplement
BHT-412EPX-MMS Maintenance Manual Supplement

ACCOMPLISHMENT INSTRUCTIONS:

1. Prepare the helicopter for maintenance.
2. Gain access to the forward pylon area by removing panel assemblies 212-030-276-001 and 412-030-237-101 located in the center fuselage (Figure 1).
3. Gain access to the center floor area by removing panel assembly 412-030-378-101 (Figure 2).
4. Remove hydraulic tube assembly 212-076-342-001 for relocation of the engine 1 N1 control cable as shown (Figure 3).
5. Locate bracket assembly 412-060-715-113 as shown and install rivets with sealant (C-251) (Figure 4 and Figure 5 sheet 3).

CAUTION

DO NOT KINK OR APPLY SHARP RADIUS BENDS TO THE
N1 CONTROL CABLE DURING INSTALLATION OR DAMAGE
TO THE N1 CONTROL CABLE MAY OCCUR.

-NOTE-

It is recommended that you do not tighten the fasteners until the required routing and orientation of the N1 control cables is achieved, to prevent twisting, interference, chafing, and preloading. Clamp orientation may require adjustments to ensure engine control throttles smoothness, and no fouling conditions exist between the cables and components or surrounding structure.

-NOTE-

Unless stated otherwise, remove and retain all hardware, including clamps, for use during the installation procedure.

6. Use Figures 5 and 6 to correctly route and secure the N1 control cable installation in the center fuselage area. Detailed instructions are included in the Figures.
7. Install hydraulic tube assembly 212-076-342-001 after relocation of the engine 1 control cable as shown (Figure 3).
8. Once the N1 control cable installation is complete, verify that both throttles operate smoothly over the entire range of operation and that there is no fouling.
9. Install the previously removed center fuselage panels 212-030-276-001 and 412-030-237-101 (Figure 1).
10. Install the previously removed center floor panel 412-030-378-101 (Figure 2).
11. Make an entry in the helicopter logbook and historical service records indicating compliance with this Alert Service Bulletin.

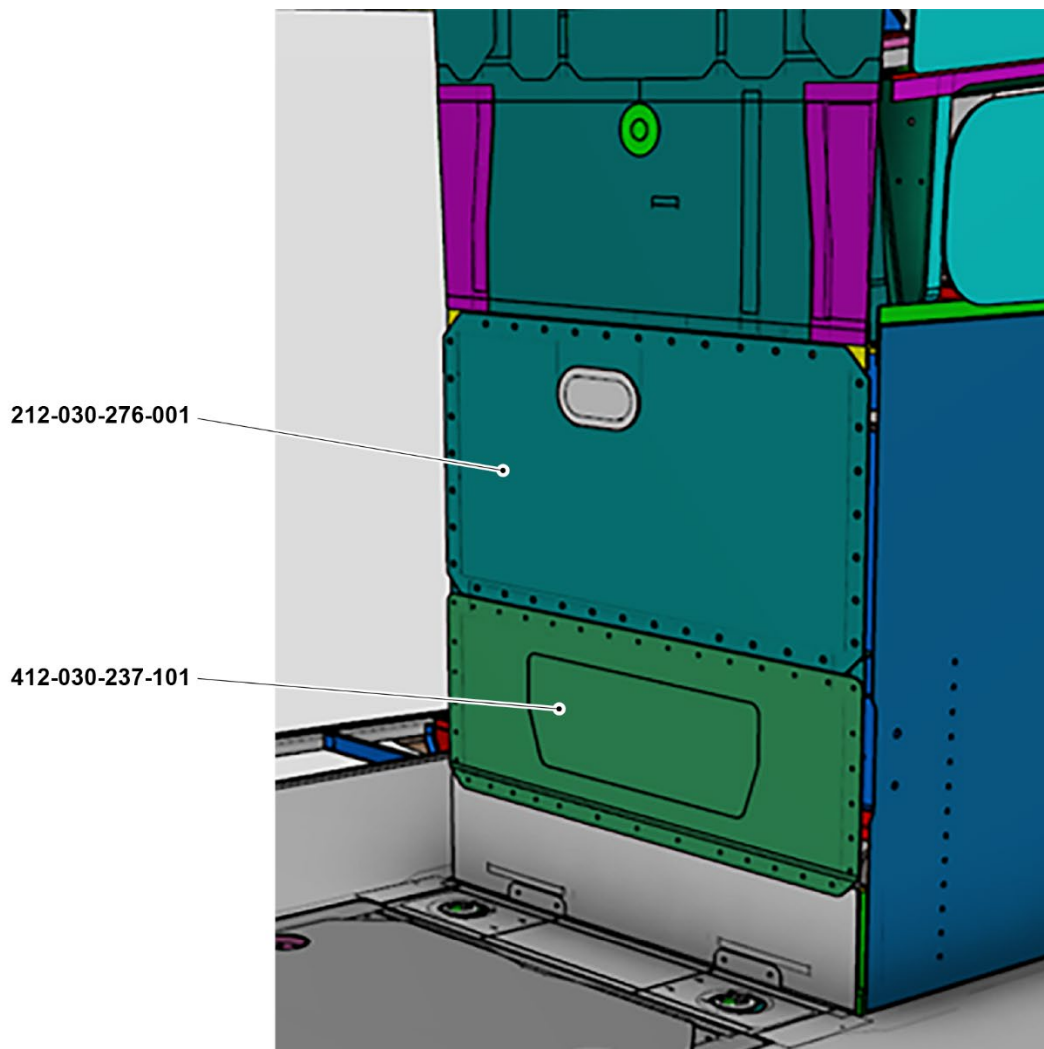

24543_001

Figure 1. Forward pylon area center fuselage panel assemblies.

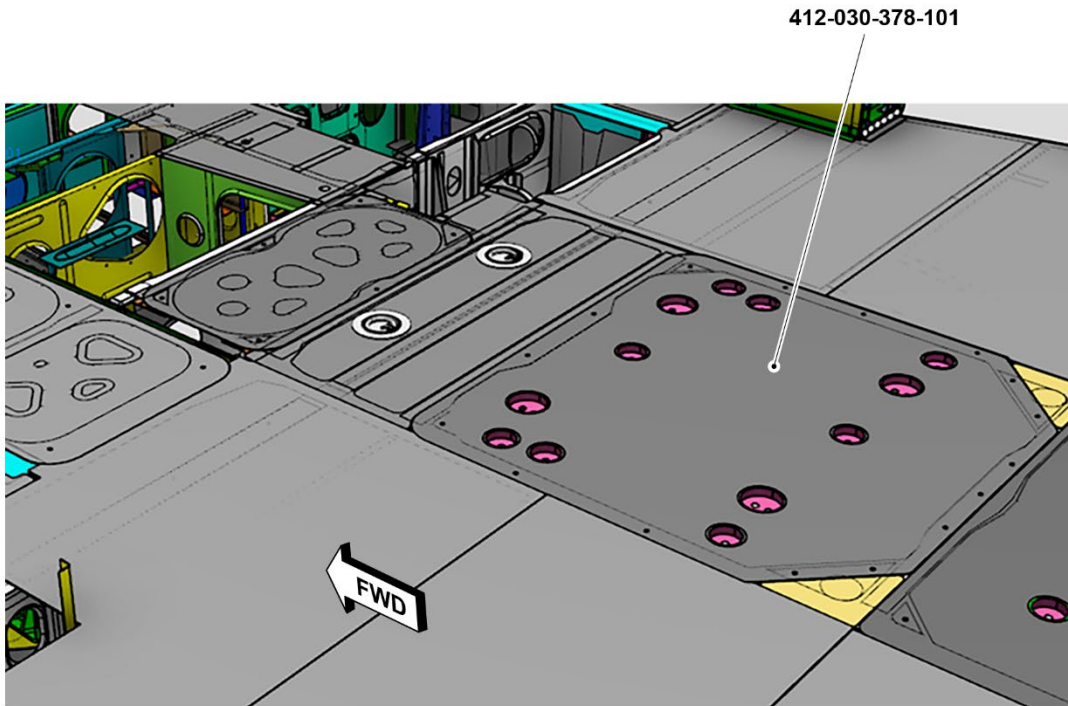

24543_002

Figure 2. Center floor panel assembly.



**PRE N1 CONTROL RELOCATION
VIEW LOOKING AFT**

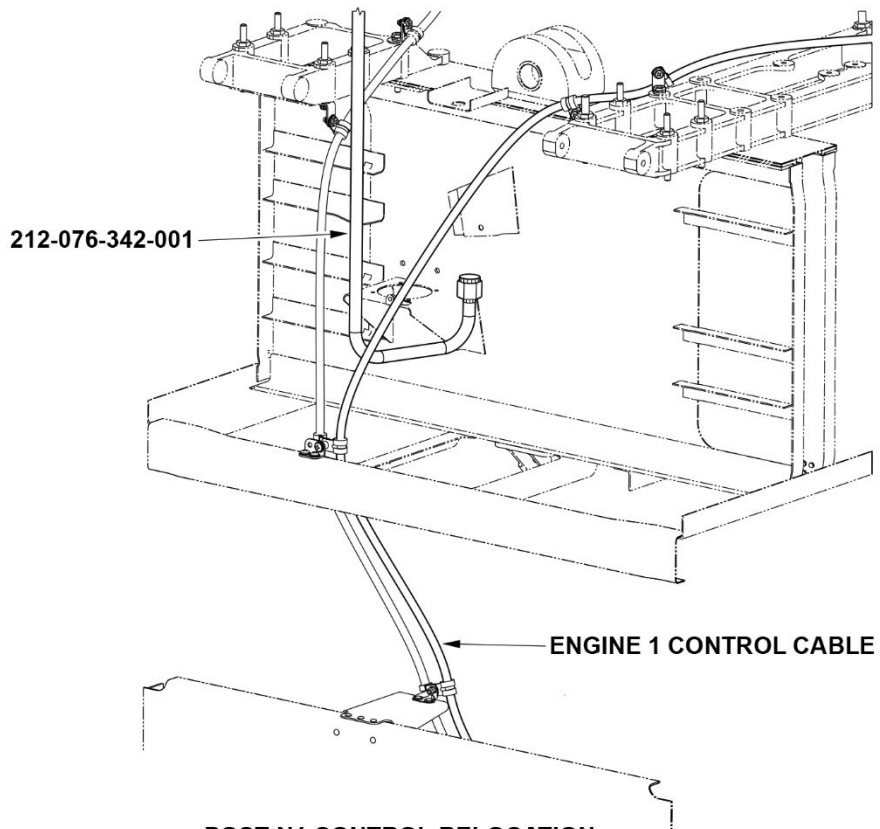

**POST N1 CONTROL RELOCATION
VIEW LOOKING AFT**

24543_003

Figure 3. Engine 1 N1 control cable, pre and post relocation.

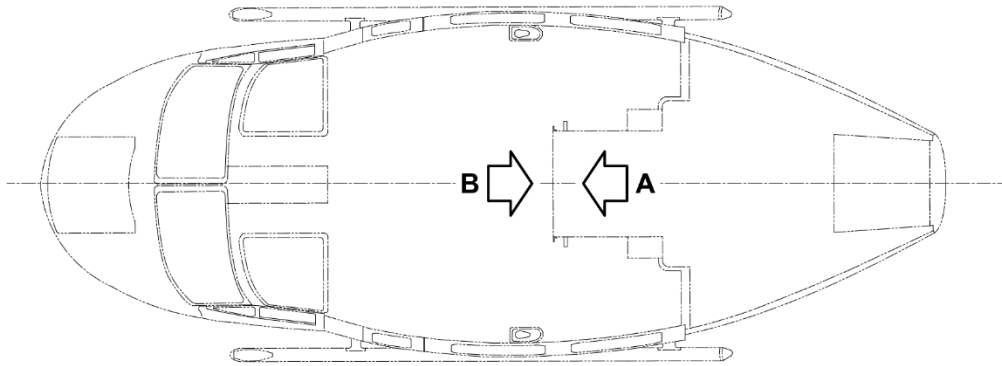

LOOKING DOWN

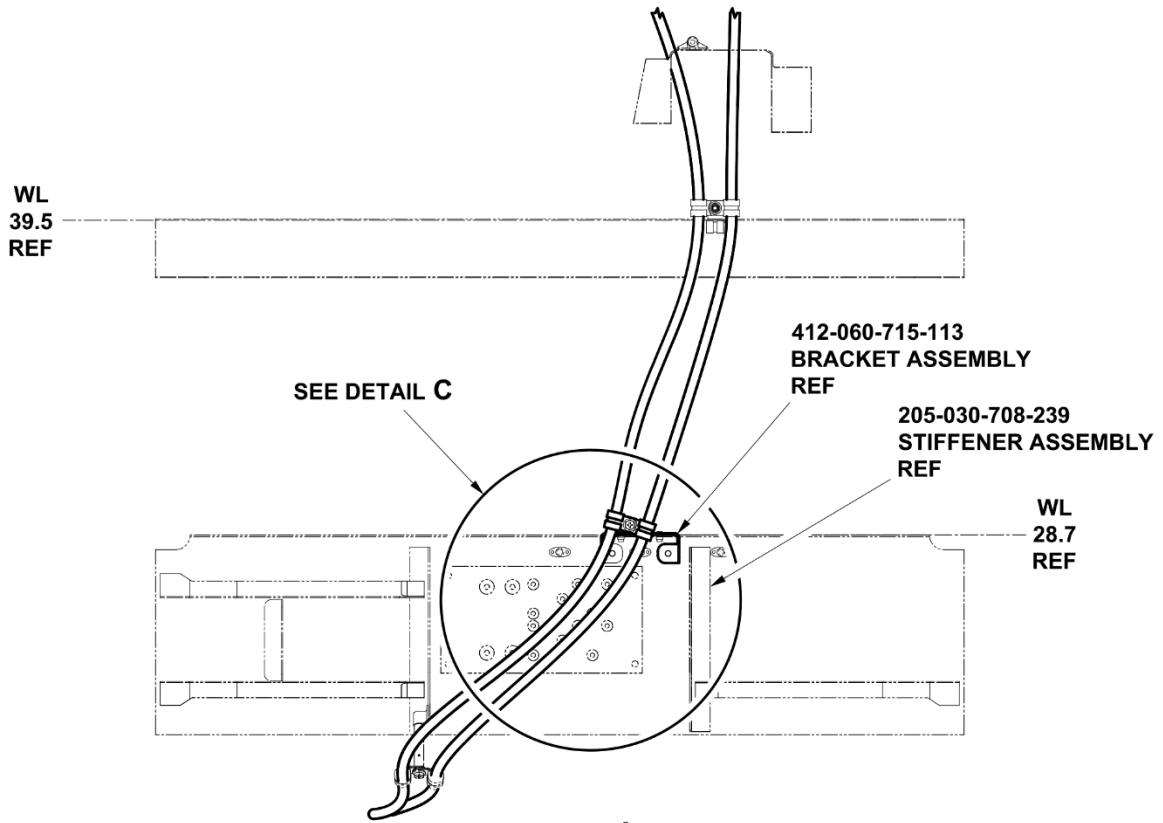

VIEW A
 ROTATED 90°CW
 DETAILS OMITTED FOR CLARITY

24543_004a

Figure 4 (sheet 1 of 3). Bracket 412-060-715-113 installation.

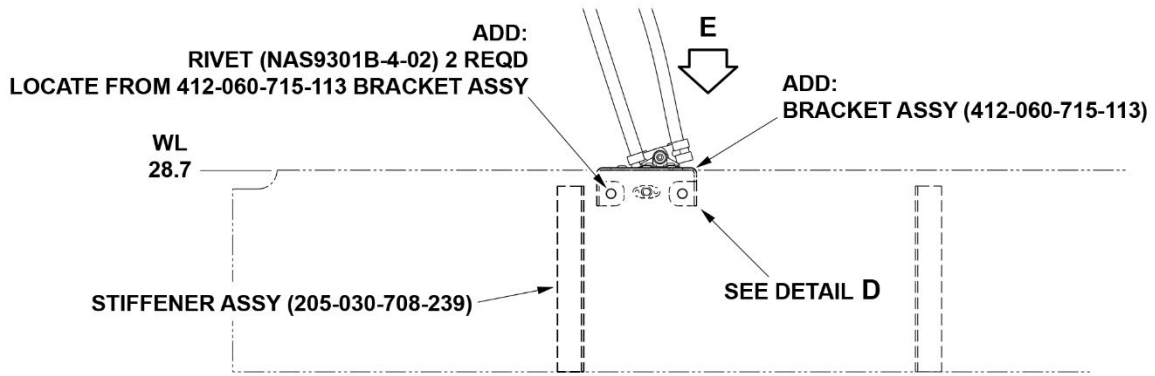

VIEW B
 ROTATED 90° CCW
 DETAILS OMITTED FOR CLARITY

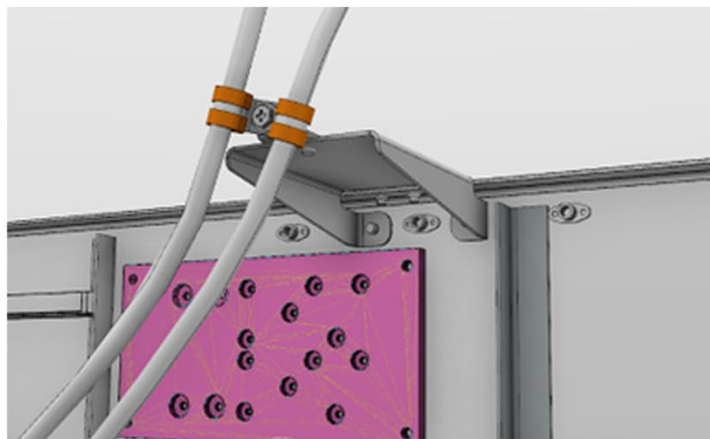

DETAIL C

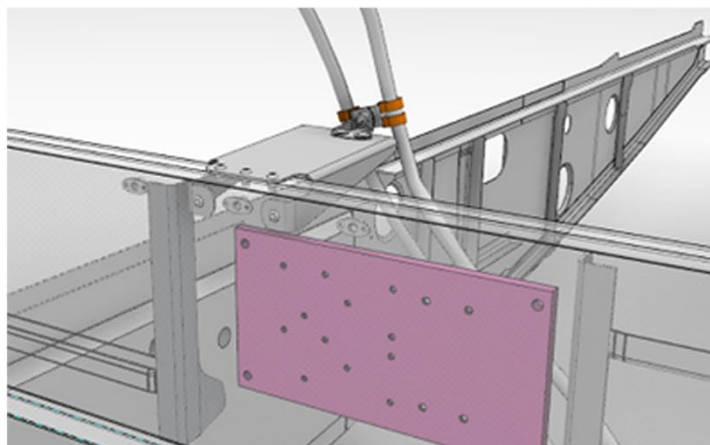

DETAIL D

Figure 4 (sheet 2 of 3) Bracket 412-060-715-113 installation

24543_004b

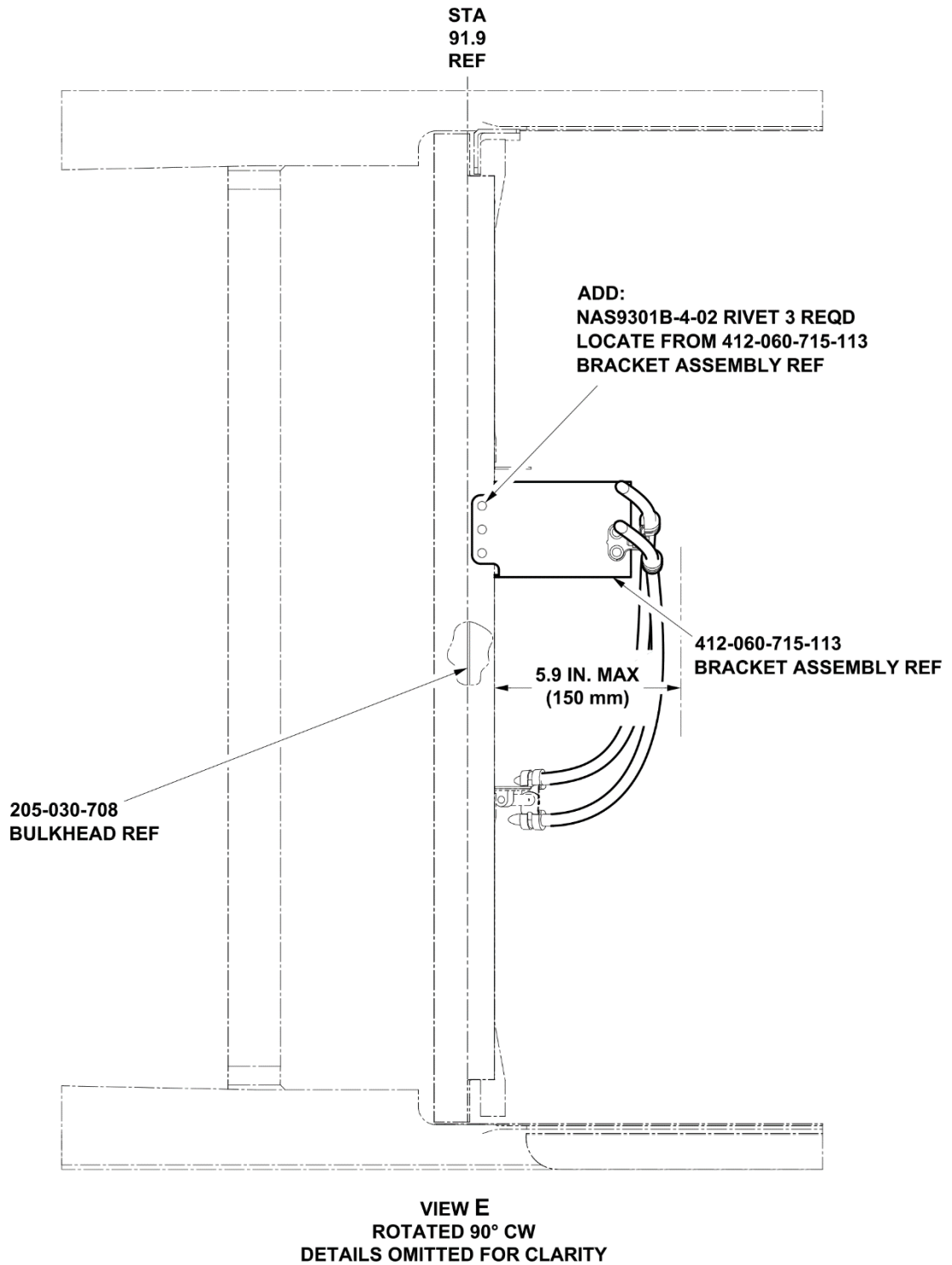

24543_004c

Figure 4 (sheet 3 of 3). Bracket 412-060-715-113 installation.

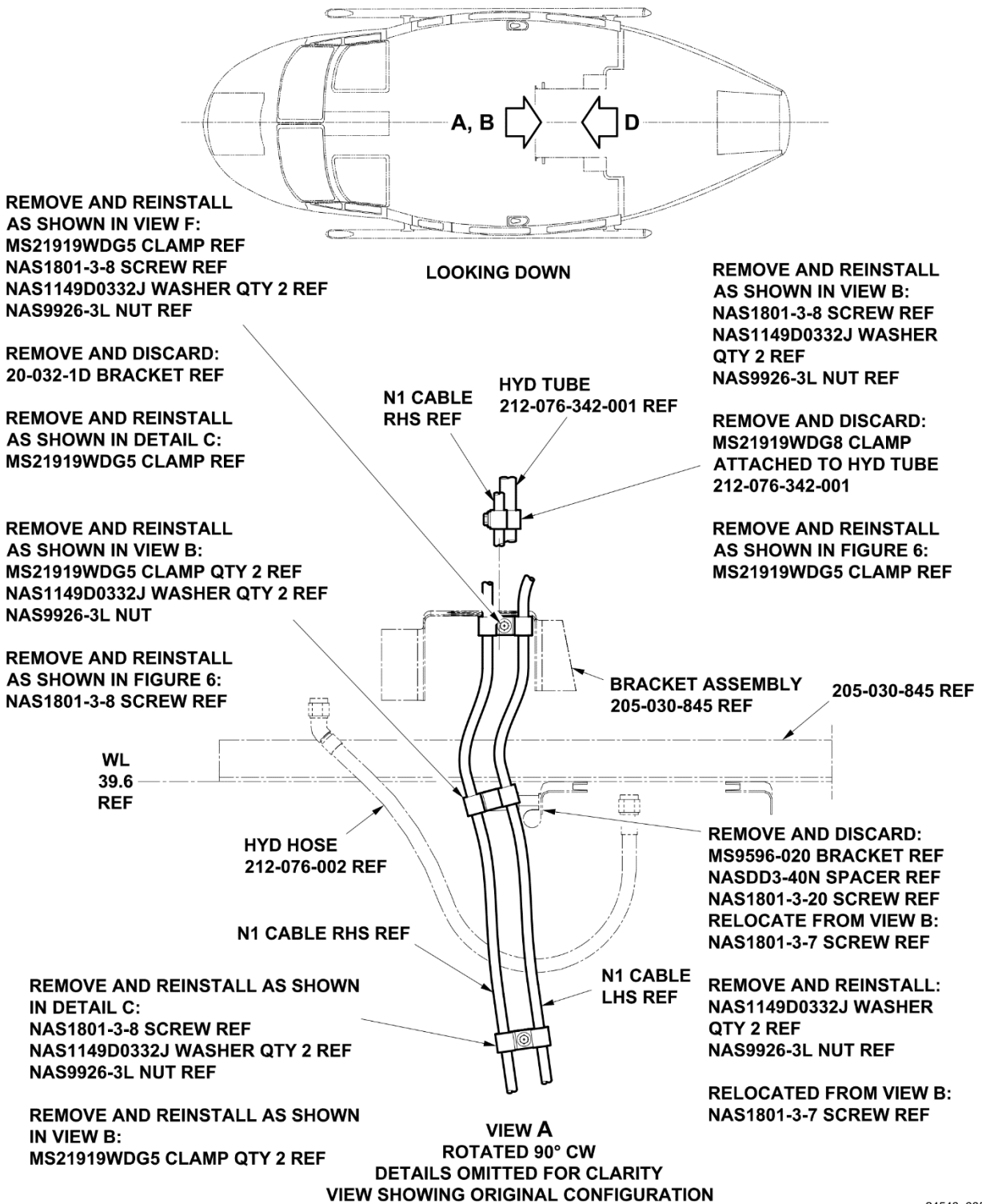

24543_005a

Figure 5 (sheet 1 of 6). Post ASB configuration center fuselage.

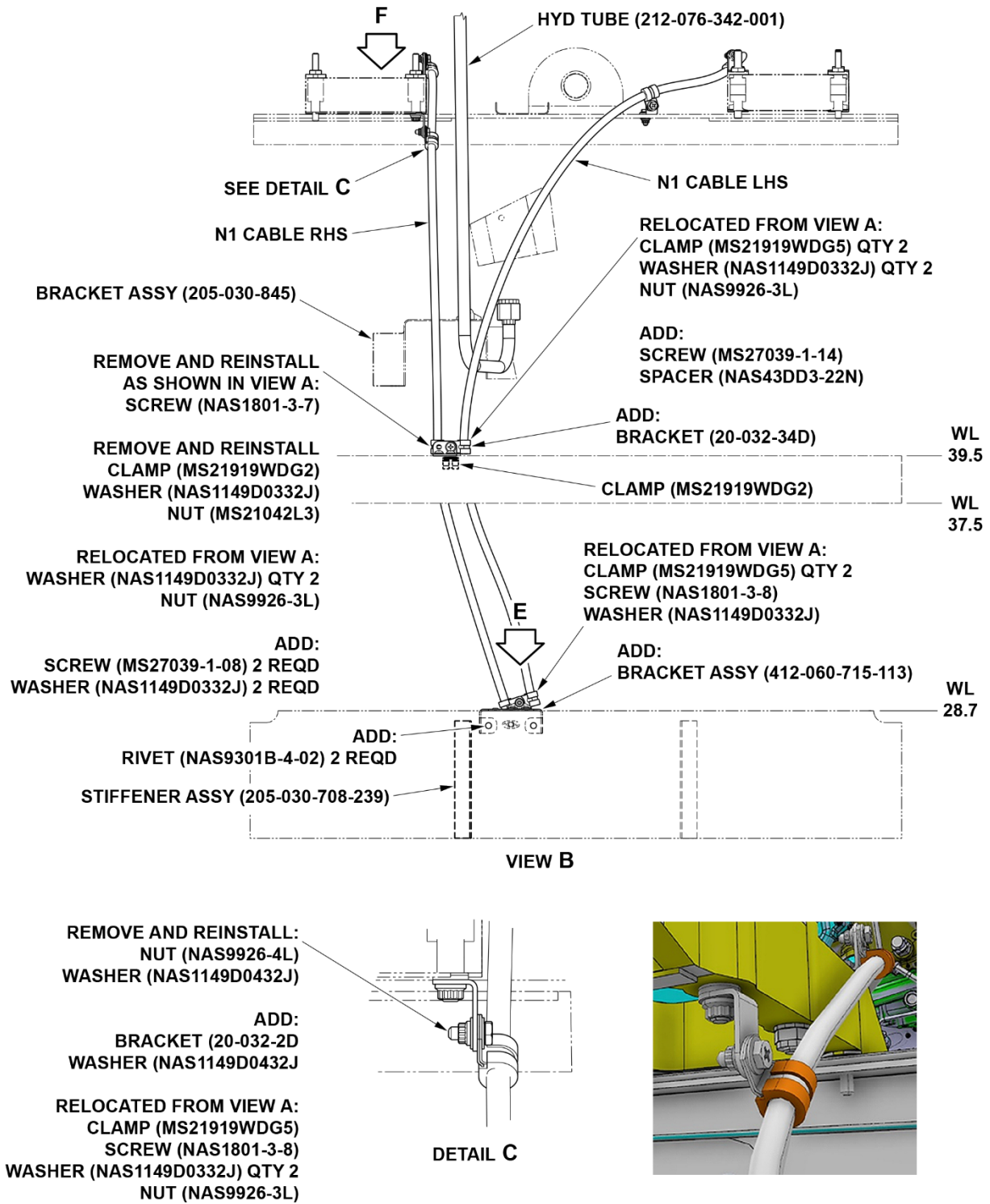
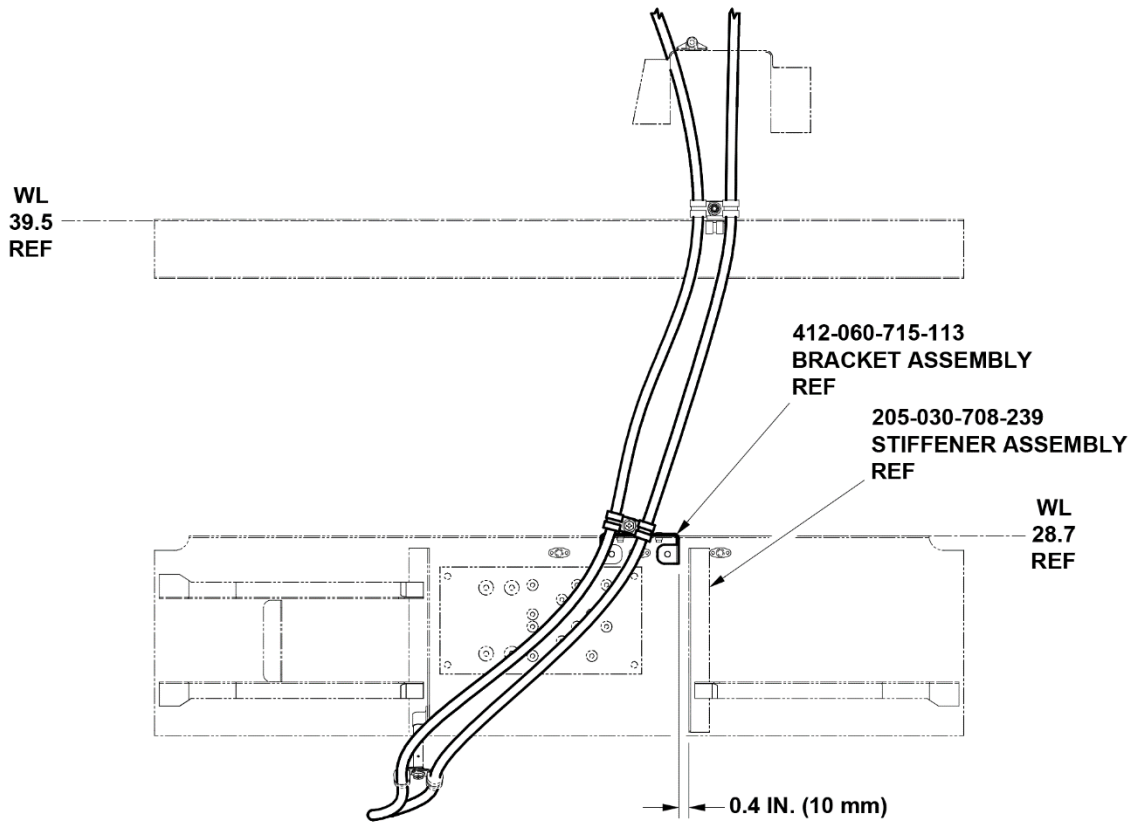

Figure 5 (sheet 2 of 6). Post ASB configuration center fuselage.



VIEW D
 ROTATED 90° CW
 DETAILS OMITTED FOR CLARITY

24543_005c

Figure 5 (sheet 3 of 6) Post ASB configuration center fuselage.

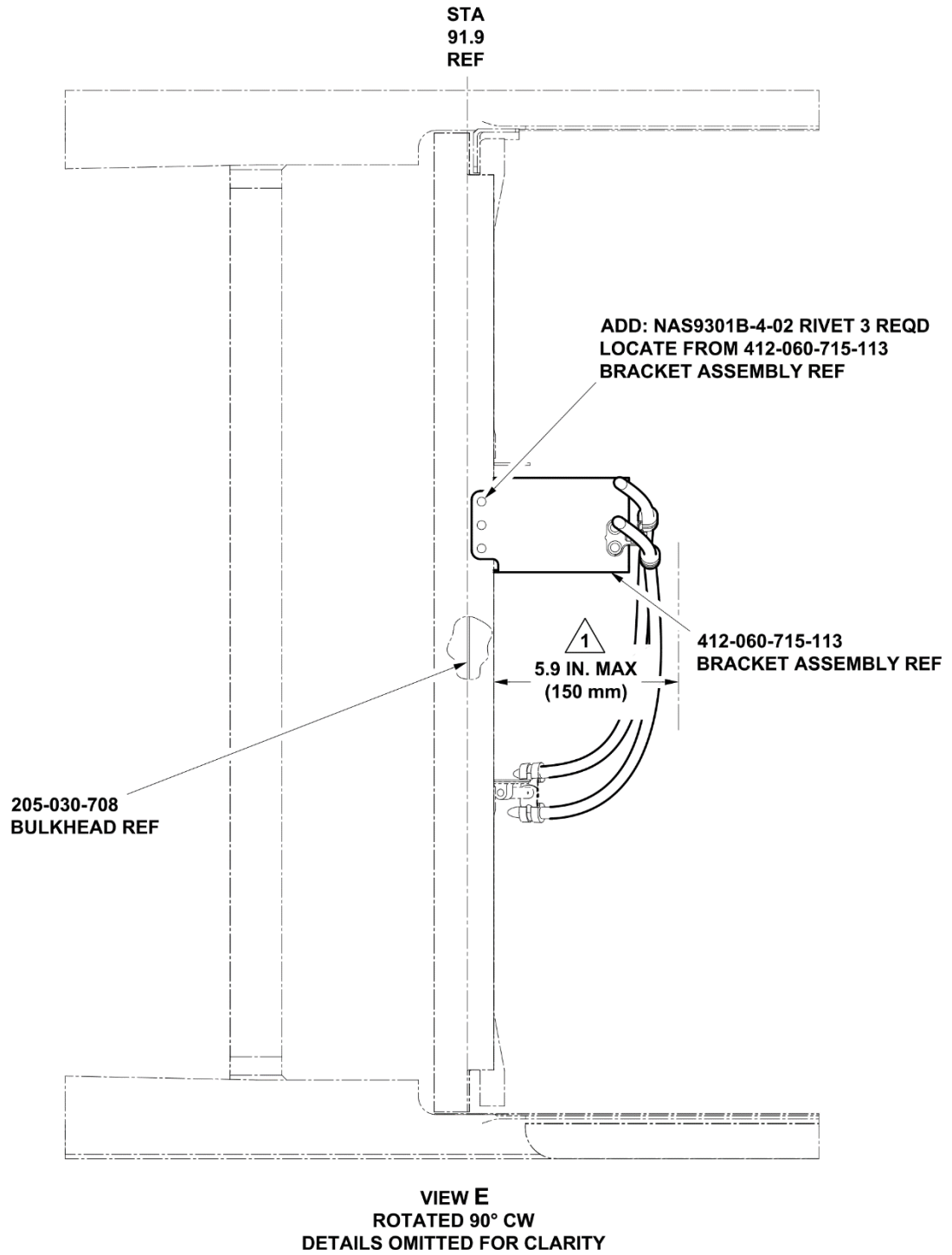

24543_005d

Figure 5 (sheet 4 of 6). Post ASB configuration center fuselage.

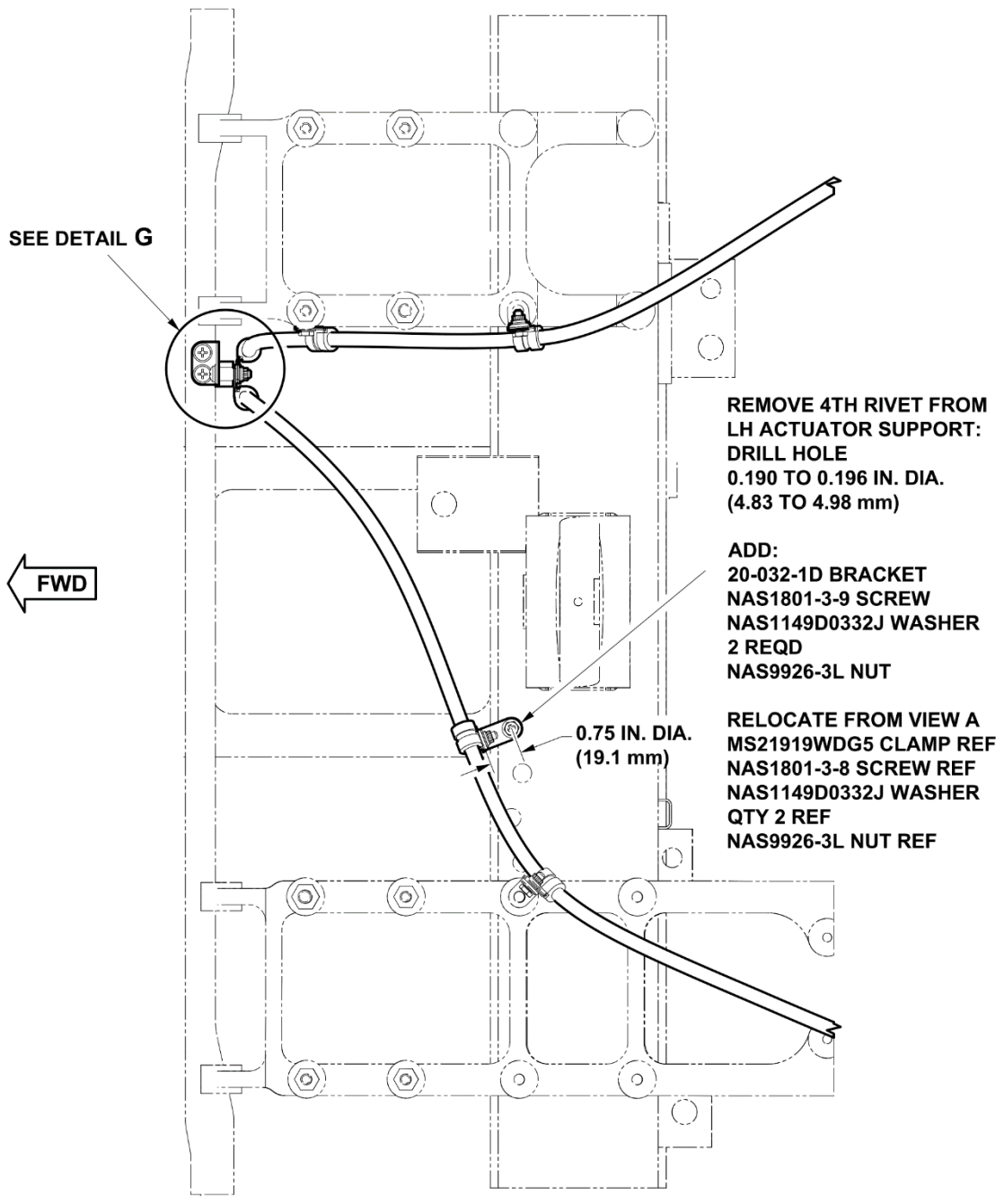

VIEW F
 ROTATED 90°CW
 DETAILS OMITTED FOR CLARITY

24543_005e

Figure 5 (sheet 5 of 6). Post ASB configuration center fuselage.

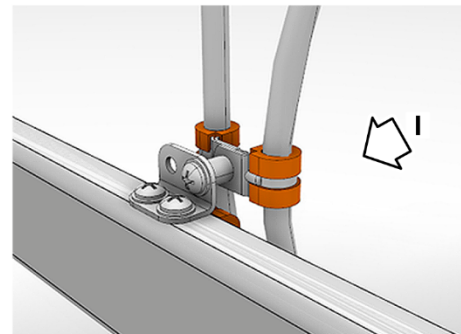
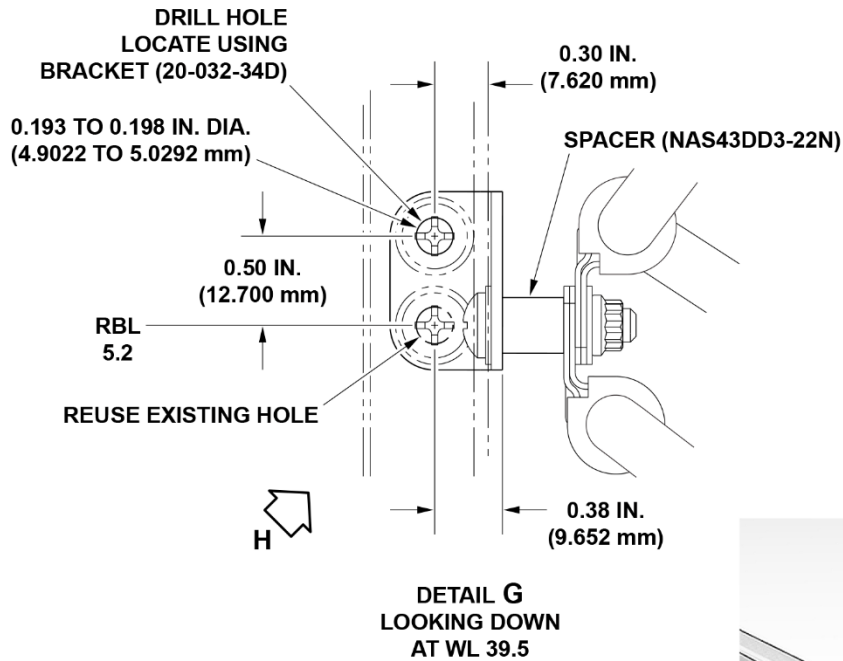

VIEW H

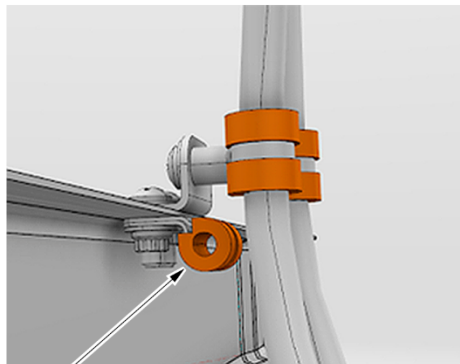

VIEW I

NOTE



Maximum distance between N1 control cables and bulkhead must not exceed indicated value to ensure no fouling exists between the cargo suspension assembly when installed and pushed forward against the bumper assembly.

24543_005f

Figure 5 (sheet 6 of 6). Post ASB configuration center fuselage.

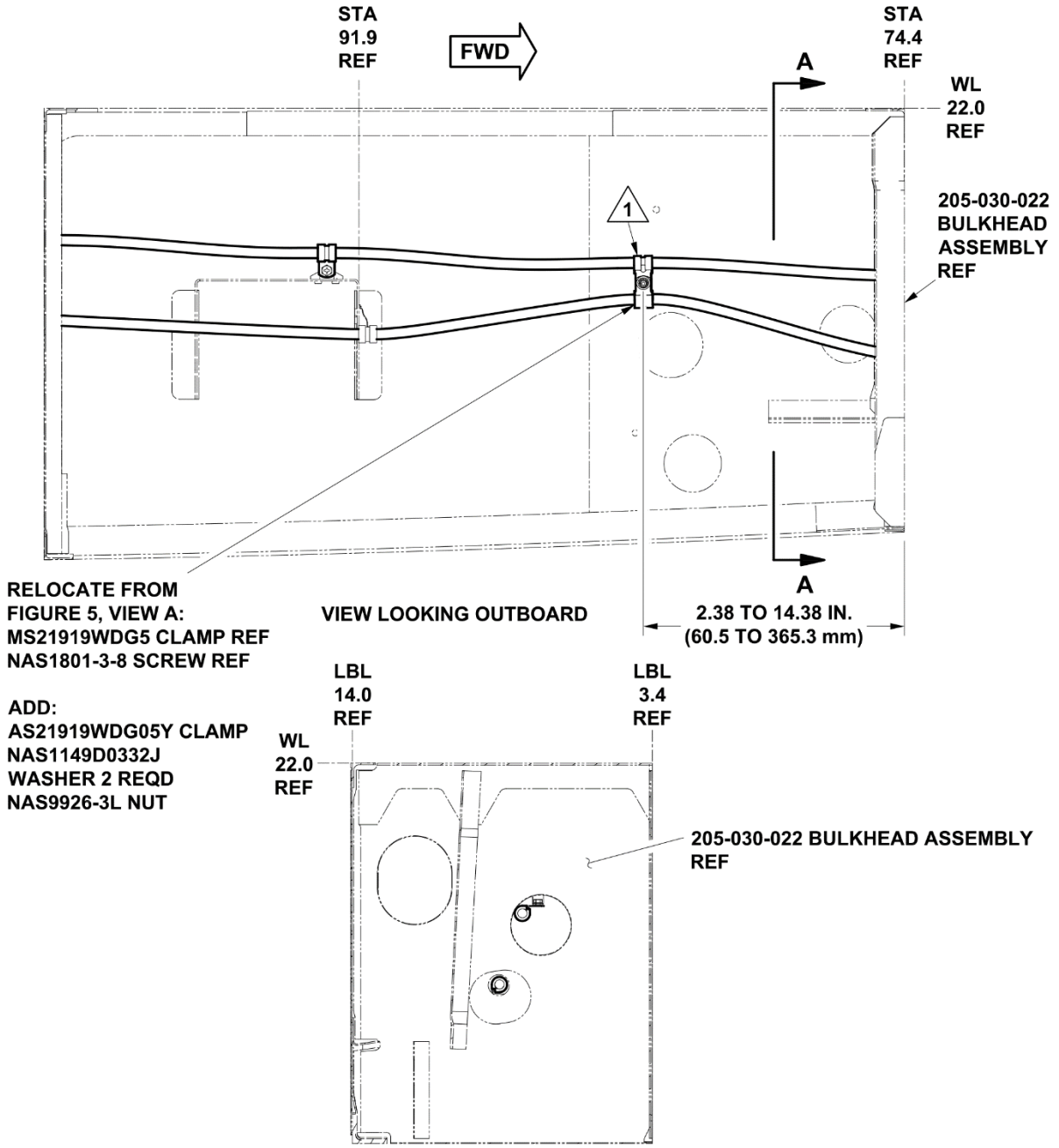

NOTE

1 Locate clamping arrangement to avoid fouling between the N1 control cables and the 205-030-022 bulkhead assembly.

24543_006

Figure 6. Post ASB configuration center floor.