

# **Bell Helicopter** **TEXTRON**

A Subsidiary of Textron, Inc.

Nov 28, 2005

## **INFORMATION LETTER 407-05-87**

**TO: All Owners/Operators of Bell 407 Helicopters**

**SUBJECT: FILTER 50-075-1, INSPECTION AND RECALL OF**

This information letter is issued to report that in some filter units 50-075-1, the screen portion of the filter was not manufactured with the correct number of holes. Testing has confirmed this condition is not detrimental to the normal operation of the transmission and freewheel oil system. However, Bell Helicopter recommends that filter units with an incorrect hole pattern be identified and replaced.

To identify the configuration to be removed from service, examine the screen hole pattern (refer to Figure 1). Replace any unacceptable filter unit at your earliest convenience.

Bell Helicopter will supply parts necessary to perform this task, consisting of packing M83248/1-906 and filter 50-075-1, at no charge. This credit is available for non-compliant filters that are installed or in stock.

To receive this credit, purchase the required part from an approved BHTI supply source. Submit a completed MMIR to BHTI warranty Dept. no later than 30 days after the replacement filter is installed in your aircraft or replaced in your stock.

Owner/Operators who comply with this Information Letter after 30 November 2006 are not be eligible for this special warranty credit.

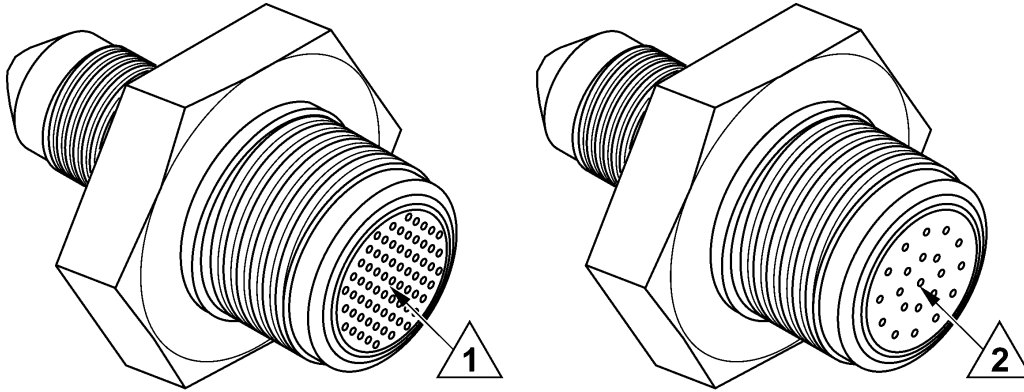

## NOTES

- 1** Acceptable hole pattern. A minimum of 65 holes are required.
- 2** Unacceptable hole pattern to be removed from service.

05561001

Figure 1. Filter 50-075-1 Physical Difference