

**ALERT SERVICE BULLETIN
REVISION NOTICE**



DATE March 31, 2008

TO: All Owners/Operators of Bell 430 Helicopters

SUBJECT: REVISION "C" TO ALERT SERVICE BULLETIN 430-04-31:

**TAIL ROTOR BLADE P/N 222-016-001-123, -123M, -131 AND -139M, INSPECTION
AND REWORK OF**

Revision "C" to this bulletin corrects the E-Mail address for Rotor Blades Inc and extends compliance date from May 31, 2008 to December 31, 2008.

AN APPROPRIATE ENTRY SHOULD BE MADE IN THE AIRCRAFT LOGBOOK UPON ACCOMPLISHMENT
IF OWNERSHIP OF AIRCRAFT HAS CHANGED PLEASE FORWARD TO NEW OWNER

ALERT SERVICE BULLETIN
Bell Helicopter **TEXTRON**

A Subsidiary of Textron Inc.

NO. 430-04-31

DATE AUG 27, 04

PAGE 1 of 13

DATE Mar 31, 2008

REV C

MODEL AFFECTED: 430

SUBJECT: TAIL ROTOR BLADE P/N 222-016-001-123,
-123M, -131 AND -139M, INSPECTION AND
REWORK OF

HELICOPTERS AFFECTED: Model 430 helicopters serial number 49001 through 49107.

Tail rotor blades 222-016-001-123, 222-016-001-123M, 222-016-001-131 and 222-016-001-139M

Tail rotor blade 222-016-001-131 and/or -139M serial numbers A-2049, A-2055, A-2060, A-2070, A-2071, A-2085 and subsequent have the intent of this Alert Service Bulletin accomplished prior to delivery and do not require recurrent inspection per Part I and Part II of this bulletin

Model 430 helicopters serial numbers 49108 and subsequent, which include blades 222-016-001-139 with no letter on the data plate after the part number will not be subject to this bulletin

-NOTE-

Installation of bearings P/N 222-312-761-101 in tail rotor blades 222-016-001-123 and -131 per Part I of Technical Bulletin 430-06-41 reidentifies the blades to -123M and -139M respectively. However, it does not eliminate the recurrent blade inspections introduced by Part I and II of this bulletin.

-NOTE-

New blades P/N 222-016-001-139 with no letter on the data plate after the part number do not require the inspection per Part I and Part II of this bulletin

-NOTE-

Tail rotor blades identified with an "R" code in the square block below the P/N field of the ID plate have already been reworked to the requirements of Part III of this bulletin and do not require the inspection per Part I and Part II of this bulletin

COMPLIANCE:

Part I: As soon as possible following receipt of this bulletin but no later than the next scheduled inspection and every 3 flight hours maximum thereafter for all tail rotor blades.

Part II: As soon as practical within the next 50 hours of operation and every 50 hour inspection thereafter for all tail rotor blades.

Part III: As soon as practical following receipt of this bulletin but no later than December 31, 2008, all affected tail rotor blades should be reworked to eliminate recurring inspection requirements introduced by Part I and Part II of this bulletin

C

DESCRIPTION:

Bell Helicopter has received three reports of cracked tail rotor blades. The cracks in two blades, started at the outboard feathering bearing bore and ran chordwise towards the leading edge on one blade and towards the trailing edge on the other blade. In the third blade, the crack started at the inboard feathering bearing bore and ran spanwise towards the inboard end of the blade. In all cases, the cracks were detected during scheduled inspections. Investigation revealed that the cracks originated from either a machining burr or a corrosion site in the bearing bore underneath the flanged sleeves.

Part I of this bulletin introduces, at intervals not exceeding 3 flight hours, a mandatory repetitive visual inspection of the blade root end around the feathering bearings, for all 222-016-001-123, -123M, -131 and -139M tail rotor blades

Part II of this bulletin introduces a mandatory 50 hour inspection of the blade root end around the feathering bearings, for all 222-016-001-123, -123M, -131 and -139M tail rotor blades.

PART III of this bulletin provides instructions to rework affected tail rotor blades in order to eliminate the recurring inspections introduced per Part I and Part II of this bulletin.

APPROVAL:

The engineering design aspects of this bulletin are Transport Canada approved.

MANPOWER:

No additional manhours will be required to accomplish part I of this bulletin when done in conjunction with the aircraft preflight check and/or the scheduled inspection. Approximately 2.0 man-hours are required to complete part II of this bulletin. Approximately 6.0 man-hours are required to replace the tail rotor hub and blades assembly to comply with Part III of this bulletin.

Man-hours are based on hands-on time, and may vary with personnel and facilities available.

WARRANTY:

Owner/operators of affected tail rotor blades who comply with the instructions outlined in this bulletin, will receive 100 % warranty coverage for the rework of the blade, provided their tail rotor blade meets the rework requirements. This bulletin must be accomplished no later than 31 December 2008.

Only tail rotor blades that are acceptable candidates for the rework or replacement as outlined in this ASB are eligible for warranty coverage. If blades are received and discrepancies are found that renders the blade as scrap or the blade has discrepancies that are not related to the ASB rework program, the blade will be returned to the customer in "as is" condition and no warranty credit or rework will be considered.

The tail rotor blade rework program only covers the following points:

- A) Remove existing bearings
- B) Remove existing bearing sleeves
- C) Clean-up blade bearing bores
 - Corrosion and Machining burrs on edges of spar
- D) Inspect root doublers for correct bonding
 - New doublers installed as required
- E) Install serviceable or new bearing sleeves as required
- F) Install new bearings
- G) Application of sealant around sleeves
- H) Re-identification of blade

Operators with affected blade(s), which have accumulated less than 4000 hours, have two options:

-NOTE-

Tail rotor blades with more than 4000 hours in service are not eligible for rework due to economic reasons. Do not ship those blades to Rotor Blades, Inc for rework.

1) Operator must contact Rotor Blades, Inc. to schedule an appointment for the rework of their blade(s) to insure the least amount of aircraft downtime.

The operator is required to send their blade(s) for rework, along with the original Historical Service Record to the following address:

Rotor Blades, Inc
580 St. Etienne Rd. Suite A
Broussard, La 70518 USA
Tel: 337-839-2119
Fax: 337-839-2122
E-Mail: cfrederick@rotor-blades.com

c

-NOTE-

The customer is to use Bell Helicopter Federal Express Account number (07520109-5) exclusively for all shipments of their blades to Rotor Blades, Inc. The freight for shipping your blades will not be covered by warranty if the above Federal Express Account number is not used.

Rotor Blades, Inc. will file all rework MMIRS on behalf of the customer. No customer action will be required to file a DMR or MMIR for a reworked blade.

2) Operators may exchange their blade(s) with either new or reconditioned blade(s). Order a replacement blade from Bell Helicopter Textron Supply Center and file a warranty claim. The appropriate pro-rated warranty credit will be issued based on a 5000 hour lifetime of the returned blade. Removed blade(s) must be shipped to Bell Helicopter CPR using Federal Express Account number (07520109-5) listed above. To obtain an RMA number, refer to the latest revision of Information Letter GEN-04-98.

-NOTE-

Bell helicopter has a very limited quantity of tail rotor blades available for this exchange program. Tail rotor blades will be released on a first come first serve basis. Contact your spares administrator for details and availability.

Operators with affected blade(s), which have accumulated 4000 hours or more since new, have two options:

-NOTE-

Tail rotor blades with more than 4000 hours in service are not eligible for rework due to economic reasons. Do not ship those blades to Rotor Blades, Inc for rework.

- 1) Continue to perform the 3 hour and 50 hour inspection per Part I and Part II of this bulletin until the blade reaches the listed retirement life.
- 2) Order a replacement blade from Bell Helicopter Textron Supply Center and file a warranty claim. The appropriate pro-rated warranty credit will be issued based on a 5000 hour lifetime of the returned blade. Removed blade(s) must be shipped to Bell Helicopter CPR using Federal Express Account number (07520109-5) listed above. To obtain an RMA number, refer to latest revision of Information Letter GEN-04-98.

-NOTE-

You may receive a reconditioned blade as a replacement blade

MATERIAL:

Consumable Material:

The following material is required to accomplish this bulletin, but may not require ordering, depending on the operator's consumable material stock levels. This material may be obtained through your Bell Helicopter Textron Supply Center.

| <u>Part Number</u> | <u>Nomenclature</u> | <u>Quantity</u> | <u>Reference</u> |
|---------------------|-------------------------------|-----------------|------------------|
| TT-N-95,TYII 1GAL | ALIPHATIC NAPHTHA | 1 GAL. | C-305 |
| SCOTCHBRITE TY-A | ABRASIVE PAD | 1 roll | C-407 |
| MIL-P-85582,TY1,CL2 | EPOXY POLYAMIDE PRIMER KIT | (1GAL, 1QT) | C-246 |
| MILC85285TYI-27925 | POLYURETHANE COATING,WHITE | 1 Gal. | C-245 |
| MILC87936TYI 5GAL | DERTERGENT | 5 GAL | C-318 (note 1) |

Note 1: Detergent MIL-C-87937 is an alternate to detergent MIL-C-87936.

SPECIAL TOOLS:

None required

WEIGHT AND BALANCE:

Not affected

ELECTRICAL LOAD DATA:

Not affected

REFERENCES:

BHT-430-MM-2, Chapter 5

BHT-430-MM-7, Chapter 64

BHT-430CR&O-3, Chapter 64

BHT-430-FM-1, Section 2

BHT-ALL-SPM

OSN 430-03-05, Tail rotor blade 222-016-001-ALL, periodic inspection of

OSN 430-04-06, Tail rotor blade 222-016-001-131

TB 430-06-41, Tail rotor blades 222-016-001-139 and yoke 222-012-702-113,
introduction of

PUBLICATIONS AFFECTED:

BHT-430-MM-2, Chapter 5

BHT-430-FM-1, Section 2

ACCOMPLISHMENT INSTRUCTIONS:

Part I: Accomplish this repetitive inspection every 3 flight hours maximum for all tail rotor blades 222-016-001-123, -123M, -131 and -139M.

-NOTE-

Tail rotor blades identified with an "R" code in the square block below the P/N field of the ID plate have already been reworked to the requirements of Part III of this bulletin and do not require the inspection per Part I and Part II of this bulletin

1. Pilot or maintenance personnel must check the tail rotor blade as follows:

CAUTION

Solvent must be used at ambient temperature. Do not use strong solvents such as MEK, Acetone, Lacquer thinner etc.

- a. Wipe down both surfaces of each blade around the blade feathering bearings using aliphatic naphtha (C-305) or detergent (C-318) or equivalents. Refer to Figure 1.
 - b. Closely examine the cleaned surface, on both sides of the blade, paying particular attention to the area around both bearings. If no crack is found in the paint, the inspection is complete until next inspection.
 - c. If a crack is found in the paint, maintenance personnel must proceed with step 2.
2. Remove the suspected blade from the helicopter. Refer to BHT-430-MM-7, Chapter 64.

-NOTE-

Remove paint to the bare metal in the area of the suspected crack only.

CAUTION

Plastic Media Blasting (PMB) may cause damage to helicopter parts if untrained personnel do it

3. Remove the paint preferably using Plastic Media Blasting (PMB) (refer to BHT-ALL-SPM, chapter 3 paragraph 3-24). As a substitute to PMB, a nylon web abrasive pad (Scotchbrite) (C-407) may be used. Abrade blade surface in spanwise direction only.
4. Examine the blade with a 10X power magnifying glass. If a crack is found, remove the blade from service and contact:

Bell Helicopter Textron
Product Support Engineering
Tel: 1-800-463-3036 (Continental USA)
Tel: 1-800-463-1971 (Within Canada)
Tel: 450-437-2077 (all other areas)
Fax: 450-433-0272
E-mail: pseinter@bellhelicopter.textron.com
5. If no crack is found in the blade surface, re-finish the blade by applying one coat of MIL-P-23377 or MIL-P-85582 Epoxy Polyamide Primer so that primer overlaps existing coats just beyond the sanded area. Let dry for 30 minutes to one hour. Then apply one sealer coat of Polyurethane MILC85285 TYI CL2, color number 27925 (semi-gloss white) per Fed. Std. 595. Refer to BHT-ALL-SPM, chapter 4.
6. Re-install the tail rotor blade. Refer to BHT-430-MM-7, Chapter 64.

7. Annotate the helicopter records to reflect compliance with Part I of this bulletin.

Part II: Accomplish this inspection every 50 hour of operation for all tail rotor blades 222-016-001-123, -123M, -131 and -139M.

-NOTE-

Tail rotor blades identified with an "R" code in the square block below the P/N field of the ID plate have already been reworked to the requirements of Part III of this bulletin and do not require the inspection per Part I and Part II of this bulletin

1. Maintenance personnel must inspect the tail rotor blade as follows:

CAUTION

Solvent must be used at ambient temperature. Do not use strong solvents such as MEK, Acetone, Lacquer thinner etc.

- a. Wipe down both surfaces of each blade around the blade feathering bearings using aliphatic naphtha (C-305) or detergent (C-318) or equivalents. Refer to Figure 1.
 - b. Using a 10X power magnifying glass, closely examine the cleaned surface, on both sides of the blade, paying particular attention to the area around both bearings.
 - c. If no crack is found in the paint the inspection is complete until next inspection.
 - d. If a crack is found in the paint, proceed with step 2.
2. Remove the tail rotor blade from the helicopter. Refer to BHT-430-MM-7, Chapter 64.

-NOTE-

Remove paint to the bare metal in the area of the suspected crack only.

CAUTION

Plastic Media Blasting (PMB) may cause damage to helicopter parts if untrained personnel do it.

3. Remove the paint preferably using Plastic Media Blasting (PMB) (refer to BHT-ALL-SPM, chapter 3 paragraph 3-24). As a substitute to PMB, a nylon web abrasive pad (Scotchbrite) (C-407) may be used. Abrade blade surface in spanwise direction only.
4. Examine the blade with a 10X power magnifying glass. If a crack is found, remove the blade from service and contact:

Bell Helicopter Textron
Product Support Engineering
Tel: 1-800-463-3036 (Continental USA)
Tel: 1-800-463-1971 (Within Canada)
Tel: 450-437-2077 (all other areas)
Fax: 450-433-0272
E-mail: pseinter@bellhelicopter.textron.com

5. If no crack is found in the blade surface, re-finish the blade by applying one coat of MIL-P-23377 or MIL-P-85582 Epoxy Polyamide Primer so that primer overlaps existing coats just beyond the sanded area. Let dry for 30 minutes to one hour. Then apply one sealer coat of Polyurethane MILC85285 TYI CL2, color number 27925 (semi-gloss white) per Fed. Std. 595. Refer to BHT-ALL-SPM, chapter 4.
6. Re-install the tail rotor blade. Refer to BHT-430-MM-7, Chapter 64.
7. Annotate the helicopter records to reflect compliance with Part II of this bulletin.

Part III: Scheduling rework of affected tail rotor blades

Tail rotor blade rework consists of inspection or replacement, as required, of upper and lower doublers to prevent delamination and clean up of the pitch change bearing bores. In addition, serviceable or new bearing sleeves and new bearings will be installed and sealant will be applied at the edge of the flange to prevent moisture intrusion.

-NOTE-

During the rework at Rotor Blades, Inc. It will be possible to upgrade the blade(s) to the latest configuration by installing the new bearings 222-312-761-101 in accordance with Part I of Technical Bulletin 430-06-41.

However, note that tail rotor yoke 222-012-702-109 will also require an upgrade to 222-012-702-113 configuration per Part II of Technical Bulletin 430-06-41.

-NOTE-

Installation of bearings P/N 222-312-761-101 in tail rotor blades 222-016-001-123 and -131 per Part I of Technical Bulletin 430-06-41 reidentifies the blades to -123M/-139M.

Part III of this bulletin reidentifies the blades -123 or -123M and -131 or -139M with an "R" code in the square block below the P/N field of the ID plate.

Following rework, tail rotor blades 222-016-001-123 or -123M and 222-016-001-131 or -139M will be reidentified with an "R" code in the square block below the P/N field of the ID plate. Tail rotor blades reworked and reidentified with the code "R" will no longer require the recurring inspections introduced by Part I and Part II of this bulletin.

-NOTE-

Tail rotor blades P/N 222-016-001-123, -123M, -131 and -139M with more than 4000 hours in service are not eligible for rework due to economic reasons. However, those blades may remain in service provided they are inspected in accordance with Part I and Part II of this bulletin.

-NOTE-

Rotor Blades Inc is the only repair facility authorized to accomplish rework of the tail rotor blades

Rotor Blades, Inc
580 St. Etienne Rd. Suite A
Broussard, La 70518
USA
Tel: 337-839-2119
Fax:337-839-2122
E-Mail: cfrederick@rotor-blades.com

Operators with installed or spares tail rotor blades must contact Rotor Blades, Inc personnel to schedule blade rework for compliance with Part III of this bulletin.

| c

-NOTE-

The original historical Service Record of the blade must be forwarded to Rotor Blades, Inc along with the blade.

-NOTE-

To reduce helicopter downtime, we recommend that rework of blades be scheduled during a major inspection or maintenance event prior to the bulletin compliance requirements.

Removal and installation Instructions

1. Remove tail rotor hub and blades assembly from the aircraft. Refer to BHT-430-MM-7, Chapter 64.
2. Remove blades from the tail rotor hub assembly. Refer to BHT-430-CR&O-3, Chapter 64

-NOTE-

Rotor Blades Inc is the only repair facility authorized to accomplish rework of the tail rotor blades

-NOTE-

Operators with installed or spares tail rotor blades must contact Rotor Blades, Inc personnel to schedule blade rework for compliance with Part III of this bulletin.

3. Forward tail rotor blades to Rotor Blades, Inc to the following address:

Rotor Blades, Inc
580 St. Etienne Rd. Suite A
Broussard, La 70518 USA
Tel: 337-839-2119
Fax: 337-839-2122
E-Mail: cfrederick@rotor-blades.com

After Tail rotor blade rework

-NOTE-

If tail rotor blades were upgraded to the latest configuration by installing the new bearings 222-312-761-101 in accordance with Part I of Technical Bulletin 430-06-41 and the tail rotor yoke was upgraded to the 222-012-702-113 configuration per Part II of Technical Bulletin 430-06-41, refer to specific installation instructions listed in latest revision of BHT-430-CR&O-3, Chapter 64.

1. Install tail rotor blades on the tail rotor hub assembly. Balance tail rotor hub and blades assembly. Refer to BHT-430-CR&O-3, Chapter 64.
2. Install tail rotor hub and blades assembly on the aircraft. Refer to BHT-430-MM-7, Chapter 64.
3. Dynamic balance tail rotor hub and blades assembly as required. Refer to BHT-430-MM-7, Chapter 64.

-NOTE-

Tail rotor blades P/N 222-016-001-123/ or 222-016-001-131 may be mixed/matched on the same tail rotor hub assembly

-NOTE-

Tail rotor blades modified per TB 430-06-41, P/N 222-016-001-123M, 222-016-001-139M or new blade 222-016-001-139 may be mixed/matched on the same tail rotor hub assembly.

4. Installation of reworked blades 222-016-001-123, 222-016-001-123M, 222-016-001-131, 222-016-001-139M identified with an "R" code in the square block below the P/N field of the ID plate or new blade 222-016-001-139 with no letter on the data plate after the part number cancels the inspection requirements per Part I and Part II of this bulletin.
5. Reworked and/or new tail rotor blades will have a bead of sealant applied at the junction of the flange of the bearing sleeve and the blade on both sides of the blade to prevent moisture intrusion. Condition of the sealant (C-392) should be inspected when performing 150 hour schedule inspection. Reapply sealant (C-392) as required. Refer to BHT-430-CR&O-3, Chapter 64.
6. Annotate the helicopter records to reflect compliance with Part III of this bulletin

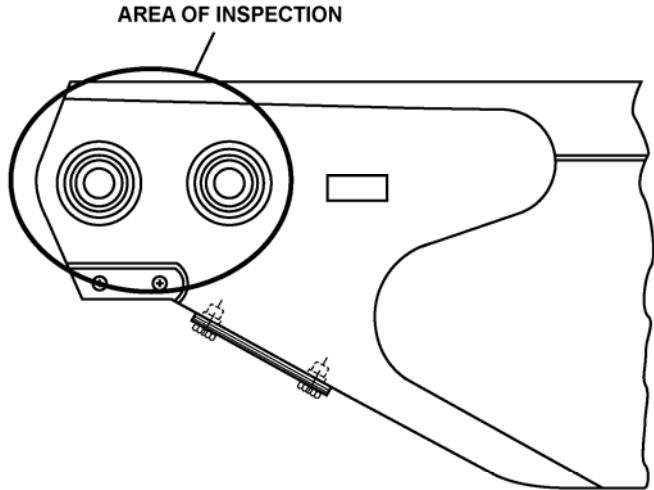

222-016-001-123

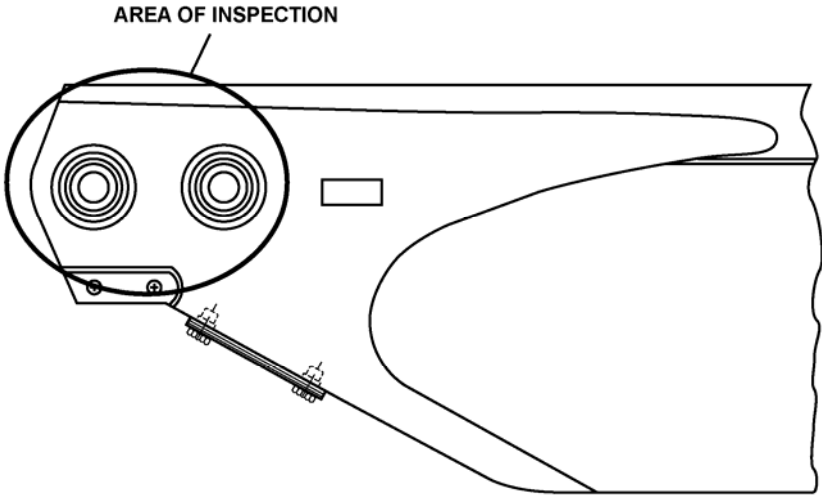

222-016-001-131

Figure 1. Blade Inspection Area