

ALERT SERVICE BULLETIN



A Textron Company

NO. 206-09-119

DATE Jan 15, 2009

PAGE 1 of 10

DATE
REV

MODEL AFFECTED: 206B

SUBJECT: VERTICAL FIN ASSEMBLY 206-020-113-231,
INSPECTION OF

HELICOPTERS AFFECTED: 206B3 Helicopters serial number 4639 thru 4665.

All 206B S/N 1252 & subsequent, all TH-57 and all TH-67 helicopters that had the vertical fin 206-020-113-231 replaced after November 01, 2007.

[206B3 helicopters serial number 4666 and subsequent, and all Spare vertical fin manufactured after October 30 2008 will have the intent of this bulletin accomplished prior delivery]

COMPONENT AFFECTED: Vertical fin assemblies 206-020-113-231 installed on a helicopter or in Spares stock having core serial number listed in Table 1.

Table 1

CORE S/N

BP4945	BP4966	BP4990	BP5012
BP4948	BP4969	BP4991	BP5014
BP4949	BP4970	BP4992	BP5016
BP4954	BP4976	BP4996	BP5018
BP4955	BP4977	BP4999	BP5019
BP4958	BP4978	BP5002	BP5020
BP4959	BP4980	BP5003	BP5024
BP4960	BP4983	BP5005	BP5029
BP4961	BP4984	BP5008	BP5032
BP4962	BP4989	BP5011	BP5035

COMPLIANCE:

PART I. Within the next 7 days after receipt of this bulletin.

PART II. Within the next 50 hours but no later than 30 days after receipt of this bulletin which ever comes first.

PART III. Within the next 300 hours but no later than March 31, 2009.

PART IV. After accomplishment of PART II and/or PART III.

DESCRIPTION:

Bell Helicopter has found that some fin assemblies 206-020-113-231 may have been manufactured with a non-conformity in the lower inner doubler area. The non-conformity is defined as a void between the lower skin inner doubler and the core that may progress with time and exceed the maximum repairable limit. The vertical fin assemblies that may be affected are identified using the core assembly serial number. The core assembly serial number can be found on the identification tag bonded on the vertical fin assembly at the location shown on Figure 1.

Part I of this bulletin provides directives to verify if one of the affected vertical fin assembly is installed on the helicopter or in Spares stock.

Part II of this bulletin provides instructions to inspect the lower area of the affected vertical fin assemblies for void.

Part III of this bulletin provides repair procedures for vertical fin assemblies that have a repairable void as defined in Part II of the accomplishment instructions. Vertical fin assemblies that have a void exceeding the repairable limits will require replacement.

Part IV provides re-identification procedure to add the suffix "V" at the end of the part number to indicate that this bulletin has been accomplished.

APPROVAL:

The engineering design aspects of this bulletin are Transport Canada Civil Aviation (TCCA) approved.

MANPOWER:

Approximately 0.2 man-hours are required to complete PART I of this bulletin. Approximately 0.5 man-hours are required to complete PART II of this bulletin. Approximately 12.0 man-hours are required to complete PART III and IV of this bulletin. Man-hours are based on hands-on time, and may vary with personnel and facilities available.

WARRANTY:

Owners / Operators of aircraft who have identified Vertical Fins on aircraft or in your stock listed in the Description section of this Bulletin will be able to apply for special warranty considerations as follows: 1) Labor credit in the amount of \$960.00 for repair the fin as per PART III only, and 2) if your fin fails to meet the requirement in PART II paragraph 3, 100% cost of a replacement fin together with a labor/paint credit of \$950.00 for removal/installation and painting of the fin .

To Receive This Credit:

- Repair the fin assembly and submit a VISTA warranty claim for labor credit of \$960.00.
- Purchase a replacement part from a Bell Helicopter approved supply source, and submit VISTA warranty claim for the replacement part invoice together with a labor/paint credit of \$950.
- Comply with this bulletin no later than March 31, 2009.

Customers that fail to comply with the instructions outlined in this bulletin before March 31, 2009 will not be eligible for the special warranty provisions listed above.

MATERIAL:**Required Material:**

The following material is required for the accomplishment of this bulletin and may be obtained through your Bell Helicopter Textron Supply Center.

<u>Part Number</u>	<u>Nomenclature</u>	<u>Quantity</u>
206-020-113-231S	Vertical fin assy	1 (Note 1)

Note 1: Vertical fin assembly will require replacement only if void exceeds repairable limits given in Part II of this bulletin.

Consumable Material:

The following material is required to accomplish this bulletin, but may not require ordering, depending on the operator's consumable material stock levels. This material may be obtained through your Bell Helicopter Textron Supply Center.

<u>Part Number</u>	<u>Nomenclature</u>	<u>Quantity</u>	<u>Reference</u>
299-947-100TY2CL2PT	Magnobond 6398 adhesive	1	C-317
MIL-PRF-81733 T2 PT	Sealant	1	C-392
ACETONE GALLON	Acetone (per Q-A-51)	1	C-316
			(Note 1)
180 GRIT CLOTH 9X11	Abrasive cloth, 180 grit	1	C-406

NOTE 1: As an alternate, use Methyl Ethyl Ketone (C-309)

SPECIAL TOOLS:

None required

WEIGHT AND BALANCE:

Weigh and balance is not affected

ELECTRICAL LOAD DATA:

Not affected

REFERENCES:

BHT-206A/B-IPB Illustrated Parts Breakdown
BHT-206A/B-MM Maintenance Manual
BHT-206-SRM-1

PUBLICATIONS AFFECTED:

None affected

ACCOMPLISHMENT INSTRUCTIONS:

PART I: Vertical fin assembly, identification of the core

1. For vertical fin in Spare Stock, proceed to step 3.
2. For vertical fin installed on helicopter, refer to BHT-206A/B-MM. Remove the tail rotor gearbox fairings to get access to the identification tag.

-NOTE-

Vertical fin assembly does not require to be removed from the helicopter.

3. Refer to Figure 1. Determine if you have an affected vertical fin assembly (1) using the serial number of the core 206-020-113-215A as listed in Table 1. An identification tag (2) showing the P/N 206-020-113-215A followed by its serial number is bonded on the fin assy as shown in the Figure 1.
4. If the serial number of the core is not listed in Table 1, reinstall the tail rotor gearbox fairing in accordance with BHT-206A/B-MM and make an entry to indicate that this bulletin has been accomplished.
5. If you have an affected vertical fin assembly, accomplish Part II of this bulletin.

PART II: Vertical fin assembly inspection

-NOTE-

Vertical fin assembly inspection does not require to be removed from the helicopter.

1. Refer to figure 1, detail A. Using the tap test method, inspect Zone 1 and Zone 2 on each side of the vertical fin assembly skin (11) in the lower area shown on the Figure 1 for voids between core (13) and inner doubler (6).
2. Record size and total area of the void, if any.
3. Verify the limit of void for each Zone. Limits are as follows for Zone 1 and Zone 2.
 - a. Zone 1 and Zone 2: If no void is found or if any single void does not exceed 0.25 square inch and the total voided area is less than 10% of the affected area, vertical fin assembly is serviceable and does not require repair or replacement. Accomplish Part IV of this bulletin.

- b. Zone 1: If any single void exceeds 0.25 square inch or if the total voided area exceeds 10% of the affected area. Accomplish Part III of this bulletin.
 - c. Zone 2: If any single void exceeds 0.25 square inch or if the total voided area exceeds 10% of the affected area. The vertical fin is not repairable and must be removed from service immediately. Order a new replacement fin and reinstall in accordance with BHT-206A/B-MM. Make an entry to indicate that this bulletin has been accomplished.
4. Notify your local CSR and Product Support Engineering that non-repairable vertical fin assembly has been removed from service and destroyed.

PART III: Vertical fin assembly repair

1. Refer to BHT-206A/B-MM. Remove tail skid assembly (3) from the vertical fin (1). Keep for reinstallation.
2. Remove the vertical fin assembly (1) from the helicopter, if installed.
3. Position vertical fin assembly (1) on a padded working table.
4. Refer to Figure 1, detail B. Remove layer of sealant covering the lower portion of the core (13).

-NOTE-

Work will be accomplished from the bottom of the vertical fin. Do not remove cured adhesive layer on inner surface of L/H & R/H inner doublers (6). Take care not to damage inner doublers (6) and skins (11).

5. Remove and route the entire honeycomb core (13) as shown in detail B with care. Exceeding the maximum area that is permitted will cause the vertical fin to be replaced.
6. Inspect the exposed area of core inside the vertical fin (1), and inner doublers (6) for corrosion, contamination, or any other damage. If such damage exists, contact Product Support Engineering for further assistance.

-NOTE-

Product Support Engineering can be reach at:
450-437-2862
1-800-363-8023
pselight@bellhelicopter.textron.com

7. Prepare surface by sanding lightly the exposed surface of inner doublers (6) with abrasive cloth (C-406) to remove glaze.

CAUTION

DO NOT SOAK PARTS TO BE BONDED WITH CLEANER (MEK, ACETONE, ETC) USE OF MOIST RAG IS RECOMMENDED. CAREFULLY AIR BLOW HONEYCOMB CAVITIES TO REMOVE DIRT PARTICLES.

8. Clean surface of the inner doublers (6) with Acetone C-316 or equivalent.
9. Position and secure the vertical fin assembly (1) upside down.
10. Fill exposed area with adhesive C-317 and allow curing at room temperature for 24 hours.
11. Inspect the repair areas for voids and unbonded areas using the tap test method. Voids shall not exceed 10% of the total area that has been repaired . No one single void shall exceed 0.25 square inch. Repeat step 5 thru 10 if any voids are exceeding these limits.
12. Seal lower edge of the vertical fin with sealant C-392 and allow to dry.
13. Refinish vertical fin assembly as required.
14. Refer to BHT-206A/B-MM. Reinstall vertical fin assy (1) on helicopter.
15. Reinstall the tail skid assy (3).
16. Accomplish Part IV of this bulletin.

PART IV: Vertical fin assembly re-identification.

1. All affected vertical fin assemblies that have complied with Part II and/or Part III of this bulletin must be re-identified as follows:
 - a. On the identification tag showing the core P/N 206-020-113-215A. Add the suffix letter "V" using a vibrating stylus and taking care not to damage tag or vertical fin skin underneath.

Example: "206-020-113-215AV PC00 BP1234 "

2. For vertical fin assembly installed on a helicopter, refer to the appropriate Maintenance Manual and re-install the tail rotor gearbox fairing.
3. For the vertical fin assembly installed on a helicopter, make an entry in the helicopter Records to indicate that this bulletin has been accomplished.

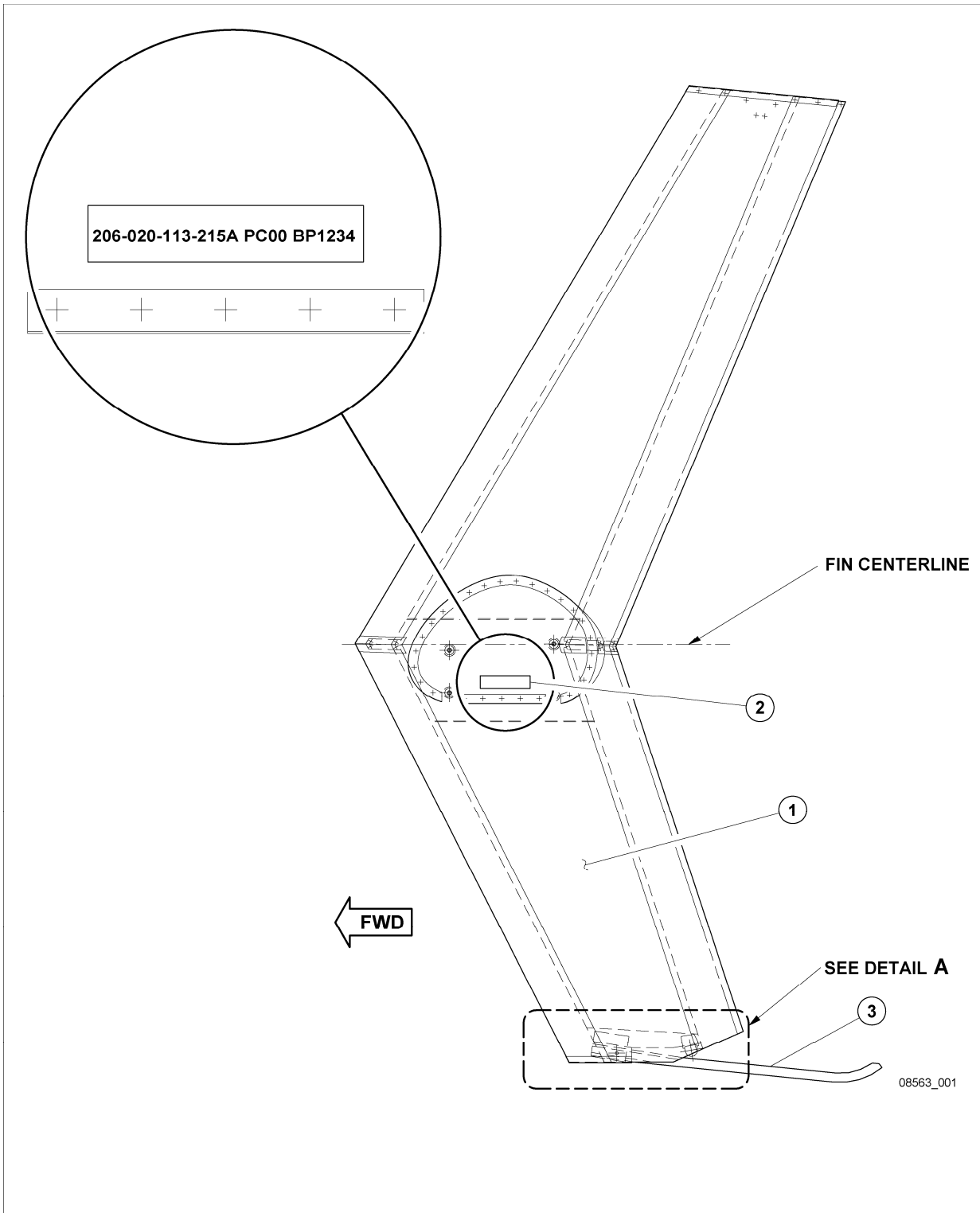
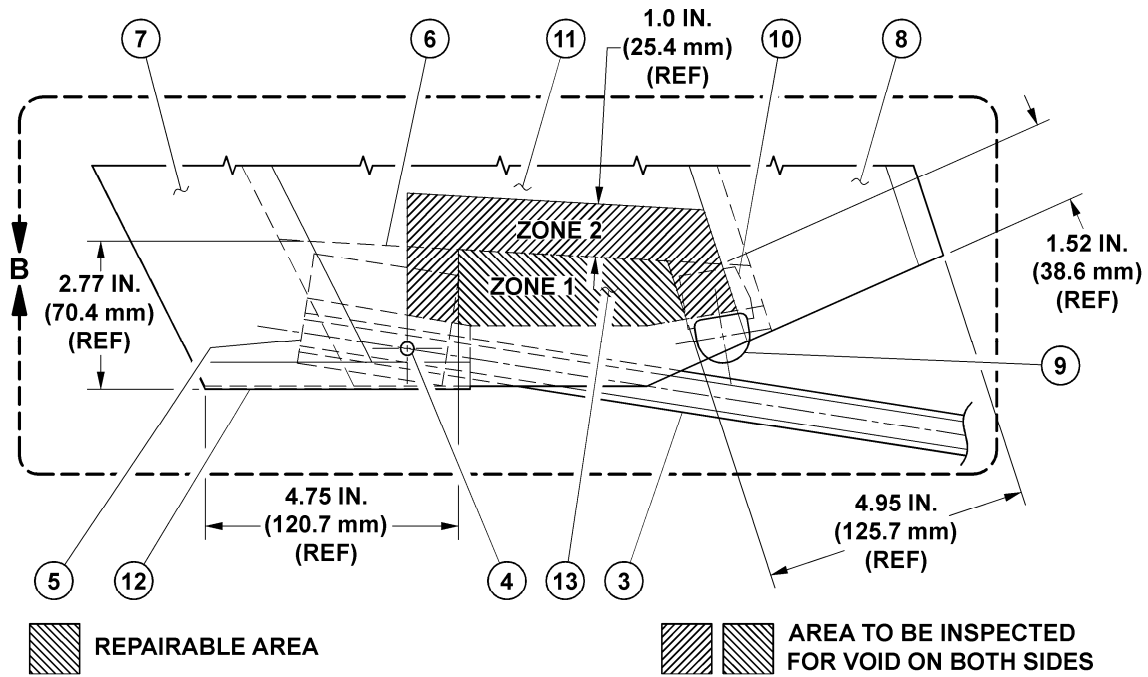
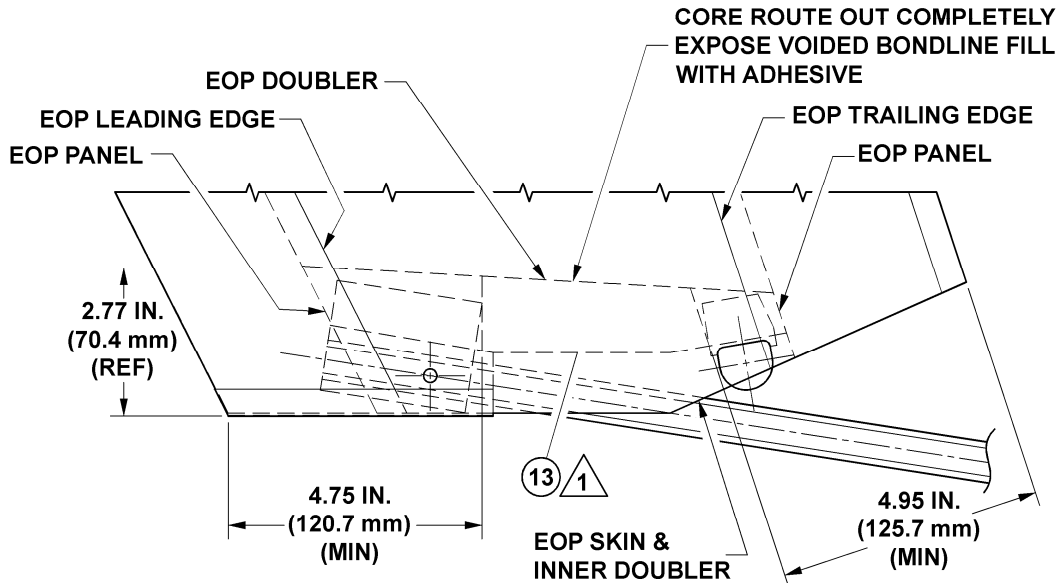

Figure 1 (sheet 1 of 2) – Vertical fin assembly, inspection and repair of



DETAIL A - INSPECTION



DETAIL B - REPAIR

- | | |
|------------------------------|----------------------|
| 1. Vertical fin assembly | 8. Trailing edge |
| 2. Identification tag | 9. Bumper |
| 3. Tail skid assembly | 10. Bumper fitting |
| 4. Pin or bolt | 11. Skin (LH and RH) |
| 5. Tail skid fitting | 12. Lower cap |
| 6. Inner doubler (LH and RH) | 13. Honeycomb core |
| 7. Leading edge | |

NOTE

1 Cover entire edge of exposed core with sealant MIL-PRF-81733.

EOP: EDGE OF PART

08565_002

Figure 1 (sheet 2 of 2) – Vertical fin assembly, inspection and repair of