

ALERT SERVICE BULLETIN
Bell Helicopter **TEXTRON**

A Subsidiary of Textron Inc.

NO. 206-05-105

DATE Nov 08, 2005

PAGE 1 of 7

DATE
REV

MODEL AFFECTED: 206A/B-SERIES and TH-67

SUBJECT: TAIL ROTOR TRUNNION HOUSING SEAL 535642
INSTALLATION, ONE-TIME INSPECTION OF

HELICOPTERS AFFECTED: Model 206A S/N 004 through 660 and 672 through 715;
Model 206B S/N 661 through 671 and 716 through 4593; [Model 206B helicopters 4594 and subsequent will have the intent of this Alert Service Bulletin accomplished prior to delivery.]

Model 206B (TH-67) 5101 through 5305. [Model 206B (TH-67) helicopters 5306 and subsequent will have the intent of this Alert Service Bulletin accomplished prior to delivery.]

PARTS AFFECTED: Tail rotor trunnion housing assembly 206-011-814-113

COMPLIANCE:

PART I:
Before installation on a helicopter

PART II:
At the next 100 hours inspection but no later than 30 days after receipt of this bulletin.

PART III a. and b.:
Before installation on a helicopter.

PART III c.:
At the operator convenience but no later than the next scheduled tail rotor hub lubrication.

DESCRIPTION:

Bell Helicopter found that some 206-011-814-113 tail rotor trunnion housing assemblies sold as spares may have been assembled with the 26001-7027 seal installed backward. Incorrect installation of the seal will prevent the bearing from getting adequate lubrication and may result in the seal being pushed out of the housing assembly during lubrication.

Part I of this Alert Service Bulletin has you perform a one-time inspection of the 206-011-814-113 housing assembly in your spare stock for correct installation of the 26001-7027 seal. This inspection is applicable to housing assemblies in spares as a detail or installed in a hub assembly.

Part II of this Alert Service Bulletin has you perform a one-time inspection of 206-011-814-113 housing assemblies that are installed on the helicopter for correct installation of the 26001-7027 seal.

PART III of this Alert Service Bulletin has you replace the 206-011-814-113 housing assembly in spares or installed on the helicopter if found with a 26001-7027 seal incorrectly installed.

APPROVAL:

The engineering design aspects of this bulletin are Transport Canada approved.

MANPOWER:

-NOTE-

Man-hours are based on hands-on time and may vary with personnel and facilities available.

Approximately 0.5 man-hour is required to complete PART II of this bulletin.

Approximately 1.0 man-hour is required to complete Part III a. of this bulletin.

Approximately 2.0 man-hours are required to complete Part III b. of this bulletin.

Approximately 6.0 man-hours are required to complete Part III c. of this bulletin.

WARRANTY:

Owner / Operators of the affected helicopters or spare housings in stock that have not been installed and comply with the instructions outlined in this bulletin and purchase a housing assembly part number 206-011-814-113 will be eligible for 100% warranty credit towards the purchase of the replacement housing assembly.

To receive this credit:

Purchase the required material from an approved BHTI supply source. Comply with the instructions outlined in this bulletin no later than 31 October, 2006. Submit a completed malfunction report to BHTI Warranty Dept. no later than 30 days after the completion of this bulletin.

-NOTE-

Customers who fail to comply with the instruction in this bulletin by 31 October, 2006 are not eligible for the special warranty considerations listed above.

MATERIAL:

The following material may be required for the accomplishment of this bulletin and may be obtained through your Bell Helicopter Textron Supply Center.

Required Material for PART III a of this bulletin:

<u>Part Number</u>	<u>Nomenclature</u>	<u>Quantity</u>
206-011-814-113	Housing Assembly	1

Required Material for PART III b and c. of this bulletin:

<u>Part Number</u>	<u>Nomenclature</u>	<u>Quantity</u>
206-011-814-113	Housing Assembly	1
047-641-175-001	Race	1
206-010-762-001	Lock washer	1 (Note 1)
B1212	Bearing	1 (Note 2)
535642	Seal	1 (Note 2)

Note:

1. Required only to perform PART III c. This is the tail rotor hub assembly attaching nut lock washer.
2. Required only if you choose to replace the seal and the bearing as noted in PART III c.

Consumable Material:

The following material is required to accomplish this bulletin, but may not require ordering, depending on facility consumable material stock levels. This material may be obtained through your Bell Helicopter Textron Supply Center.

<u>Part Number</u>	<u>Nomenclature</u>	<u>Reference</u>
MOBIL 28	Grease	C-001 (Note 1)

Note:

1. As an alternative, use AEROSHELL 22 (C-001).

SPECIAL TOOLS:

None required.

WEIGHT AND BALANCE:

Not affected.

ELECTRICAL LOAD DATA:

Not affected.

REFERENCES:

BHT-206A/B-SERIES-MM Maintenance Manual
BHT-206B3-CR&O Component Repair and Overhaul Manual
BHT-206A/B-Maintenance and Overhaul Manual
Technical Bulletin 206-96-163 (RADS-AT Installation and use of)

PUBLICATIONS AFFECTED:

None affected.

ACCOMPLISHMENT INSTRUCTIONS:**PART I: Inspection of housing assemblies in spares.**

1. Inspect new housing assembly (3, Figure 1) not installed in a hub assembly (1) for correct seal (5) installation. If the housing assembly (3) is found with the seal (5) incorrectly installed, return the defective housing assembly (3) to Bell Helicopter and order a new housing assembly (3).
2. Inspect new housing assembly (3) installed in tail rotor hub assembly (1) for correct seal (5) installation. If the housing assembly (3) is found with the seal (5) incorrectly installed, perform PART III a. of this Alert Service Bulletin.
3. Inspect housing assembly (3) installed in a hub assembly (1) with time in service for correct seal (5) installation. If the housing assembly (3) is found with the seal (5) incorrectly installed, perform PART III b. of this Alert Service Bulletin.

Part II: Inspection of housing assemblies installed on the helicopter.**-NOTE-**

Do not use a pneumatic grease gun to purge grease from the bearing (4).

1. Using a hand grease gun, purge grease (C-001) from bearing (4), by pumping grease into fitting, NAS 516 of housing assembly (3).
2. If normal purging of grease (C-001) from the bearing (4) can be achieved and the seal is not pushed out of the housing assembly (3) during lubrication, the seal performance in the new housing assembly (3) is acceptable and the helicopter may be returned to service. Make an entry in the Helicopter Records to show that Part II of this Alert Service Bulletin has been accomplished.
3. If restriction is felt and no grease is being purged from the bearing (4) through the seal (5) lip, perform PART III c. at your convenience but no later than the next scheduled lubrication.

PART III: Housing assembly replacement instructions.

PART III a.: If the housing assembly is installed on a hub assembly in spares with no time in service, proceed as follow:

1. Replace the housing assembly (3) if the seal is found to be reversed. Refer to the BHT-206B3-CR&O or to the BHT-206A/B-M&O as applicable. Make an entry in the hub assembly historical records to show that the PART III a. of this Alert Service Bulletin has been accomplished.

PART III b.: If the housing assembly is installed on a hub assembly in spares with time in service, proceed as follow:

1. Replace the housing assembly (3) and both trunnion (2) inner races if the seal is found to be reversed. Refer to the BHT-206B3-CR&O or to the BHT-206A/B-CR&O as applicable. Make an entry in the hub assembly historical records to show that the PART III b. of this Alert Service Bulletin has been accomplished.

PART III c.: If the housing assembly is installed on a hub assembly on the helicopter, proceed as follow:

-NOTE-

As an alternate mean of compliance, it is acceptable to retain the housing and replace the seal (5), the bearing (4) and the trunnion races 047-641-175-001. Refer to the BHT-206B3-CR&O or to the BHT-206A/B-CR&O for replacement procedures.

1. Remove the tail rotor hub and blade assembly from the helicopter. Refer to the BHT-206A/B-SERIES MM.
2. Replace affected housing assembly (3) and both trunnion (2) inner races. Refer to the BHT-206B3-CR&O or to the BHT-206A/B-CR&O as applicable.
3. Re-install the tail rotor hub and blade assembly on the helicopter. Refer to BHT-206A/B-SERIES-MM.
4. Ground-run the helicopter and perform a tail rotor balance check. Refer to BHT206A/B-SERIES-MM or the TB 206-96-163.
5. Make an entry in the Helicopter and the Component Historical Records to show that Part III c. of this Alert Service Bulletin has been accomplished.

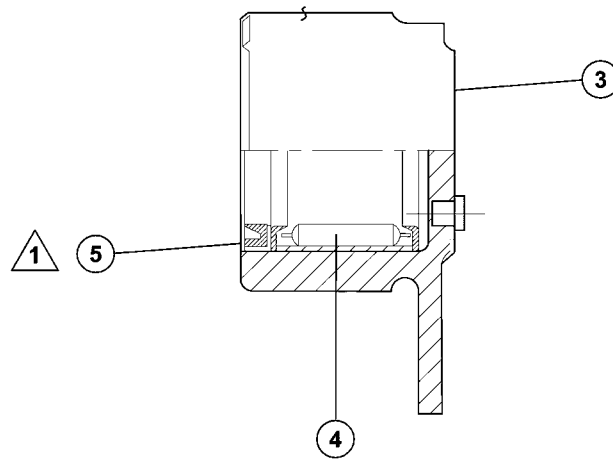
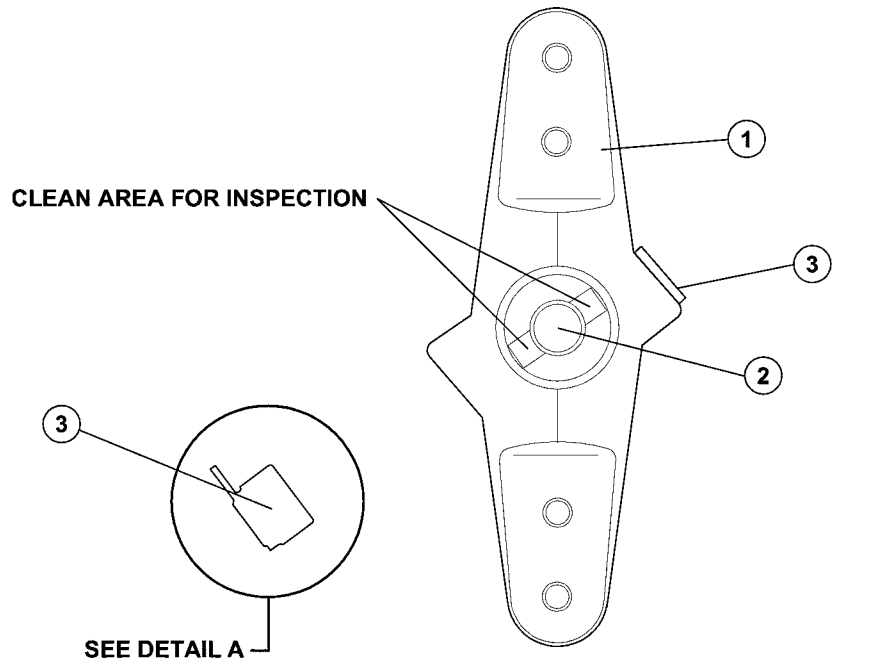

- 1. Tail rotor hub assembly
- 2. Trunnion
- 3. Housing assembly 206-011-814-113
- 4. Bearing B1212
- 5. Seal 535642

DETAIL A

NOTE
 Lip of seal facing toward the tail rotor gearbox output shaft.
Correct installation shown.

Figure 1. Correct orientation of seal in housing assembly